



Finishes You've Never Seen Before®

WESTERN STATES METAL ROOFING

(877) 787-5467 • WESTERNSTATESMETALROOFING.COM

MS2® PANEL 2" MECHANICAL SEAM

INSTALLATION GUIDE WITH TRIM, FLASHINGS AND DETAILS



Phoenix: 901 W Watkins St., Phoenix, AZ 85007
☎ (602) 495-0048
✉ sales@westernstatesmetalroofing.com

Tucson: 4975 E. Drexel Rd., Tucson, AZ 85706
☎ (520) 574-4247
✉ tucsonsales@westernstatesmetalroofing.com



Western States "MS-2® Standing Seam"

Installation, Flashings & Shop Drawing Detail Guide

Table of Contents

| Section | Page | Section | Page |
|---------------------------------------|-------------|---|-------------|
| Special Design Considerations..... | 1 | Rib Cover 3D..... | 28 |
| Notes to Designer /Installers..... | 2 | Rake Wall Detail (90 Degree Seam)..... | 29 |
| Fastener Placement and Selection..... | 3-4 | Rake Wall Detail (180 Degree Seam)..... | 30 |
| Panel Profile..... | 5 | High Eave Detail (Fixed)..... | 31 |
| Stiffening Ribs..... | 6 | High Eave Detail (Floating) | 32 |
| Eave Hem..... | 7 | Ridge Detail (Floating)..... | 33 |
| Key Flashing / Trims | 8-11 | Ridge Detail (Fixed) | 34 |
| Clip Spacing..... | 12 | Valley Detail (Fixed)..... | 35 |
| Fixed Lap Detail..... | 13 | Valley Detail (Floating)..... | 36 |
| Floating Lap Detail..... | 14 | Bull Nose Eave Detail..... | 37 |
| Swage Detail..... | 15 | Half Valley Detail (Fixed)..... | 38 |
| Fixed Eave Detail..... | 16 | Half Valley Detail (Floating)..... | 39 |
| Floating Eave Detail..... | 17 | Head Wall Detail (Floating)..... | 40 |
| Gutter Detail..... | 18 | Notes..... | 41 |
| Gutter Splice Detail..... | 19 | Custom Trim..... | 42 |
| Rake Detail (180 Degree Seam)..... | 20 | | |
| Rake Detail (90 Degree Seam)..... | 21 | | |
| Head Wall Detail (Fixed)..... | 22 | | |
| L/H Pitchbreak Detail (Fixed)..... | 23 | | |
| L/H Pitchbreak Detail (Floating)..... | 24 | | |
| H/L Pitchbreak Detail (Fixed)..... | 25 | | |
| H/L Pitchbreak Detail (Floating)..... | 26 | | |
| Rib Cover Detail..... | 27 | | |

Western States "MS-2® Standing Seam"

Installation, Flashings & Shop Drawing Detail Guide

Special Design Considerations

The details contained in this guide are proven industry details and are intended to be used as a design aid and installation guide. It does not depict all situations that may be encountered on all projects. Modifications are the responsibility of the designer/owner/installer.

Consideration should be given for fit for purpose, building use, climate conditions such as temperature, snow, wind, and moisture, governing building codes, and maintenance.

It is highly recommended that all trims and flashings be of the same material as the panels (metal, gauge, finish) to ensure long term performance and durability. Where possible, flashing edges should be hemmed to strengthen the edge and protect the cut edge from exposure.

Acceptance

Use of this manual is strictly voluntary. Details that are provided are to be used as a guide only. Details may not be applicable for all situations. This guide provides one standard detail and WSMR accepts that other installation details may be needed and other details may exist. WSMR makes no guarantee as to the weather tightness of the system or details found within this guide. The information in this manual is believed to be correct and accurate at the time of printing. WSMR reserves the right to change details, discontinue products, change designs at any time without incurring obligation. It is best to consult your design engineer for recommendations.

Underlayment

There are many types of underlayments on the market today that are all designed with a special purpose depending on the type of metal and profile. Many different types of metal will require a different type of underlayment, such as A606-4 (Corten), which requires a high temperature underlayment. It is best to consult your design engineer for recommendations.

Not all conditions require an underlayment, however, metal siding is susceptible to condensation and it is recommended that an appropriate underlayment be used on all wood substrates to protect the structure during installation. For added protection from rain and

snow, it is recommended to use rubberized ice and water shield.

Snow Design

Design and dimensions must be the proper width to accommodate high snow, rain, ice, and slope conditions. If possible, splices, penetrations, should be minimized in areas of high snow and ice accumulations. Details found in this manual may not pertain in areas of high snow and ice accumulations.

Panel coverage and fastening

Normal panel width of MS-2® Standing Seam panels are 12", 16" and 18" wide coverage. However depending on the finish selected and the required coil feed, other sizes may be available. Please consult with your WSMR representative for details and fastening recommendations.

Safety and Maintenance

Extreme care should always be used when working with metals. Safety should always be a top priority and approved fall protection and equipment as approved by OSHA should always be used. No structure is immune to severe weather, or is completely maintenance free. To keep your siding performing as it was designed, an inspection and comprehensive maintenance program should be implemented.

References

For other installation techniques and details, The Sheet Metal and Air Conditioning Contractors National Association Inc. (SMACNA) and NRCA manuals are great resources for working with sheet metal.

Technical Assistance

Contact your WSMR sales or technical representative for any additional information or assistance. To insure you have the latest information available, please inquire or visit our web sites at Paintedtrustedroofing.com or Metalforroofing.com

Western States "MS-2® Standing Seam"

Installation, Flashings & Shop Drawing Detail Guide

Notes to Designer and Installers

The details contained in this guide are proven industry details and are intended to be used as a design aid and installation guide. It does not depict all situations that may be encountered on all projects. Modifications are the responsibility of the designer/ owner/ installer. Consideration should be given for fit for purpose, building use, climate conditions such as temperature, snow, wind, and moisture, governing building codes, and maintenance. It is highly recommended that all trims and flashings be of the same material as the panels (metal, gauge, finish) to ensure long term performance and durability. Where possible, flashing edges should be hemmed to strengthen the edge and protect the cut edge from exposure.

Framing and Substrates

"MS-2® Standing Seam" panels are used over all type of substrates like steel framing, open purlins, spaced sheathing, and wood surface such as plywood. Most details in this guide are shown with panels attached to open framing.

Oil Canning

Oil canning is a condition common with flat metal surfaces. This waviness is caused by steel mill tolerances, forming, variations in the structures surfaces, and hardness of the steel. Measures are taken at the roll forming process, like profile design, steel gauge, corrective leveling, to minimize the effects of oil canning. Oil canning is a characteristic of steel and can not be eliminated totally and therefore is not reason for rejection of the panels.

Job Site Storage

While waiting to be installed on the job site, storage of panels, trim crates, and flat sheet should be sloped in order to allow for proper moisture run off. One end should be elevated so as not to allow ponding of water on the metal surface. When using tarps for protection, proper ventilation should be provided to prevent condensation. Moisture or

condensation that is trapped inside a bundle can lead to white rust on sheeting. WSMR assumes no responsibility of liability for damage to our products which occurs in the possession of the consignee or which we deem to be improper handling and storage. Protective plastic film on trim or panel should be removed within 90 days. Failure to follow these instructions may void the warranty.

Slope Requirements

The panels in this install guide should be used on slopes 1:12 or greater with mastic.

Condensation, Insulation, & Ventilation

It is the designer's responsibility to determine the need and composition of condensation control materials including insulation and vapor retarders, as well as ventilation requirements. Metal roofing is susceptible to condensation, and its control should be carefully considered.

Pinning Requirements

The MS2® panel must be "pinned" at one end only to resist the "drag" load caused by weight of the panels, live load, and snow loads. The intensity of the drag load is a function of the slope, the loads involved, and the panels. Please consult a design engineer for exact pinning requirements.

Expansion & Contraction

Both the panels and flashing must allow for expansion and contraction of the materials, especially where long lengths are used.

The overlap between the hidden cleat and the turned-under end of the panel at the eave may need to be increased to accommodate thermal movement when 30ft + sheets are used.

Valleys

Valley dimensions must be the proper width to account for roof slope, snow, ice and rain conditions. Details found in this guide may not pertain to areas of high snow and ice accumulations.

Western States "MS-2® Standing Seam"

Installation, Flashings & Shop Drawing Detail Guide

Fastener Selection

Notes to Installers:

Fastener Selection will vary depending on type and thickness of substrate. Design Calculations for clip spacing should be completed by the design engineer.

The use of Butyl tape mastic, Butyl sealants and Curing Sealants is always recommended to insure weather tight installation.

Panels and flashings should never be installed in contact with dissimilar metals. Use only those flashings and accessories designed for use with this panel.

Panel clip attachment screws must be long enough to fully penetrate through roof deck substrate or penetrate solid lumber at least one inch.

Exposed Trim Fasteners should have sealing washers and be coated to provide protection against corrosion.

Screws must be properly driven to ensure holding strength and proper seal. (see diagram)
Recommended drill speed is 2000rpm. Improper setting of drill speed can lead to snapping of screw heads.

Pre drilling of screw holes may be necessary with heavy gauge metals

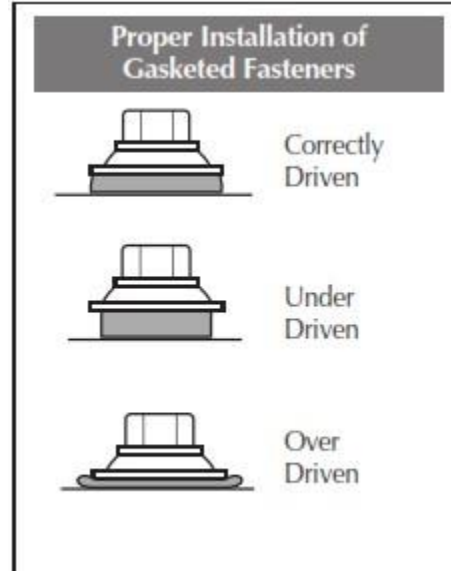

Western States "MS-2® Standing Seam"

Installation, Flashings & Shop Drawing Detail Guide

Fastener Selection

Description

Application

14 x 7/8" Lap Self tap

Used to attach trims.



#10-12 x 1" Pancake head Wood
#10-12 x 1" SD PH Self Driller Steel

Used to attach Panel clips.
Used to secure trims to substrates.

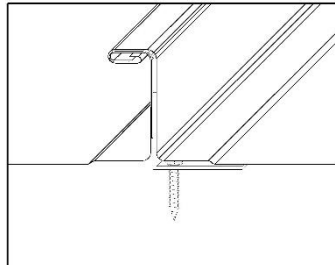
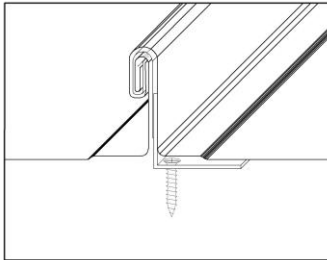

*Double Seam UL Rated

1/8" Stainless Rivets

Used for Trim to Trim attachment or trim to wall panels.



#9 x 1" Woodgrip
#9 x 1.5" Woodgrip
#9 x 2" Woodgrip

Used for panel attachment



#12-14 x 1" Self Driller
#12-14 x 2" Self Driller

Used for Metal to Metal
Used for Metal to Metal

18 ga. Floating Clip

Floating clip allows for thermal movement.

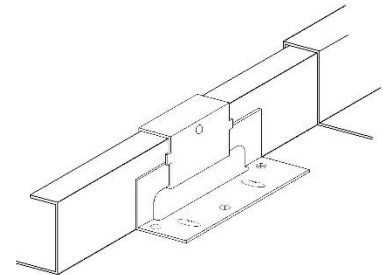

18 ga. Fixed Clip

Fixed Clip

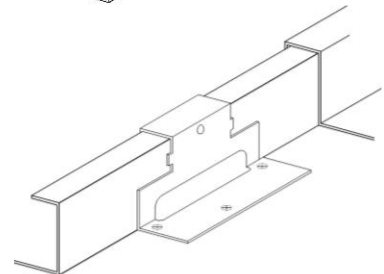

WSMR will not be responsible for final screw/clip selection. This guide is just a reference tool to be used. Please consult a design engineer for load and design calculations.

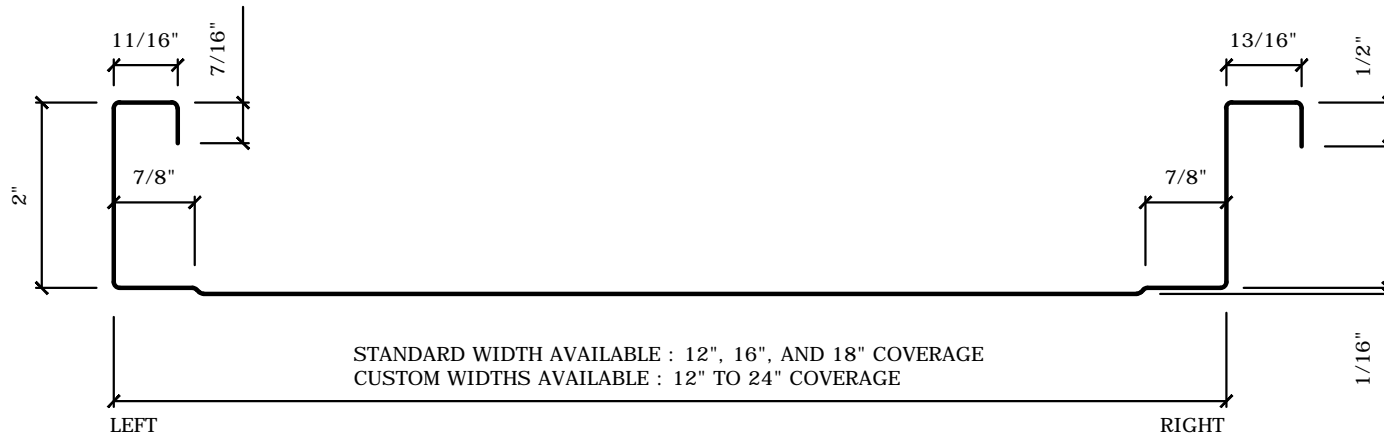
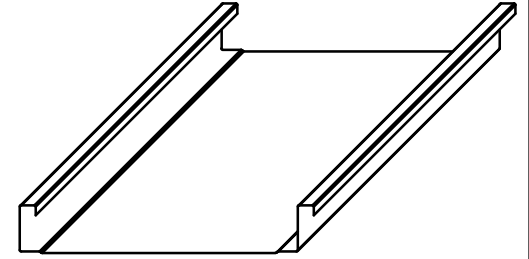

| | | | | |
|---|----------|--|----------|-------|
| Western States Metal Roofing | SCALE: | TITLE / PART NAME: MS2[®] STANDING SEAM | | |
| | DRAWN: | | | |
| | DATE: | PRODUCT / PRODUCT LINE | | |
| 901 W. Watkins St. Phoenix, AZ 85007 | CHECKED: | PART I.D. | REVISION | SHEET |
| | DATE: | | | |

Copyright: The design and print is the property of Western States Metal Roofing, and must not be used, reproduced, or copied, wholly or in part without the written permission from the company. Supply of this design and print represents a confidential communication between the company and recipient.

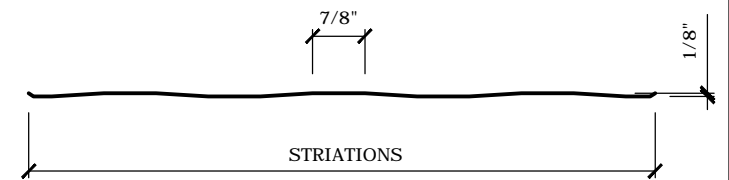
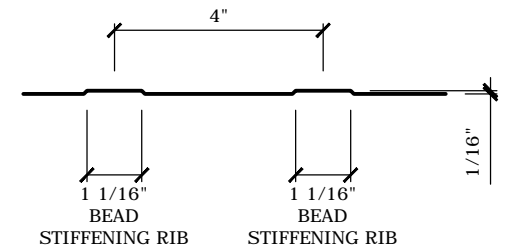
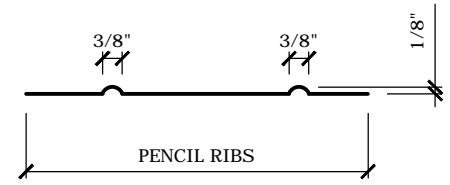
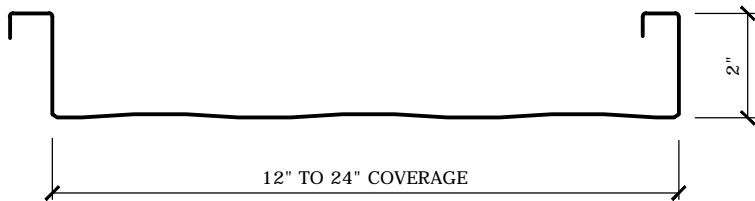
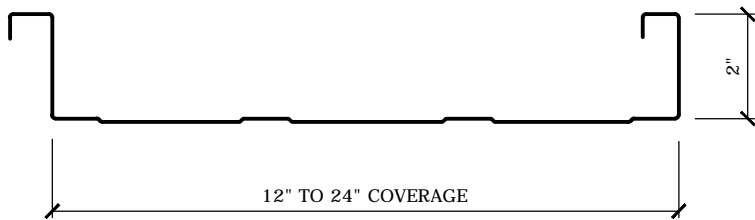
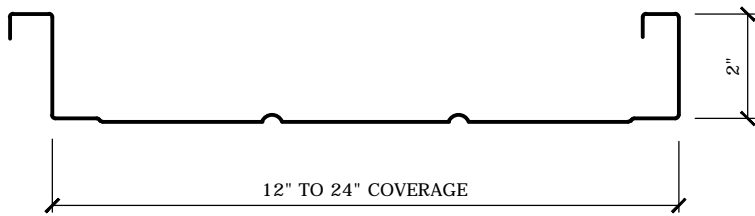

| | | | | |
|---|----------|--------------------------------|----------|-------|
| Western States Metal Roofing | SCALE: | TITLE / PART NAME: | | |
| | DRAWN: | STIFFENING RIBS | | |
| | DATE: | PRODUCT / PRODUCT LINE | | |
| 901 W. Watkins St. Phoenix, AZ 85007 | CHECKED: | MS2 [®] STANDING SEAM | | |
| | DATE: | PART I.D. | REVISION | SHEET |
| | | | | |

Copyright: The design and print is the property of Western States Metal Roofing, and must not be used, reproduced, or copied, wholly or in part without the written permission from the company. Supply of this design and print represents a confidential communication between the company and recipient.

EAVE HEM

STEP ONE

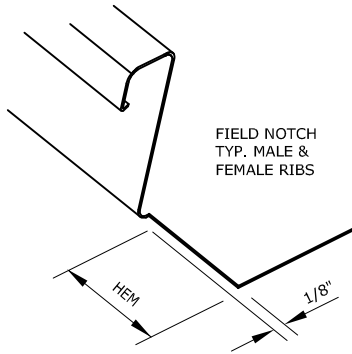

STEP TWO

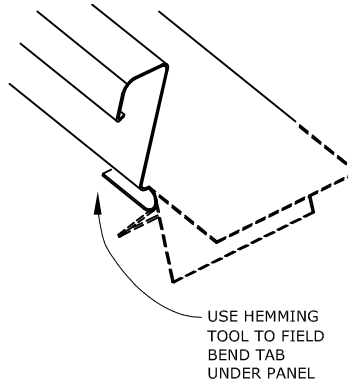

STEP THREE

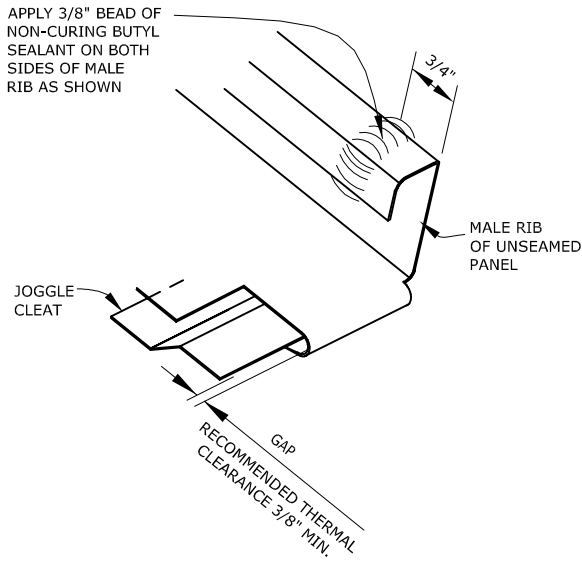

HEMMED & SEAMED
MS2[®] PANEL

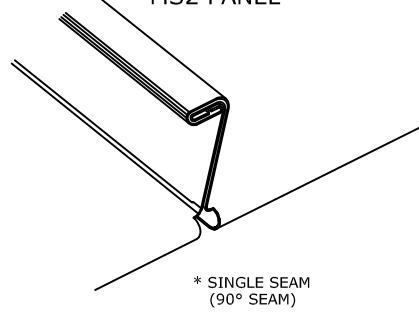

* SINGLE SEAM
(90° SEAM)

HEMMED & SEAMED
MS2[®] PANEL

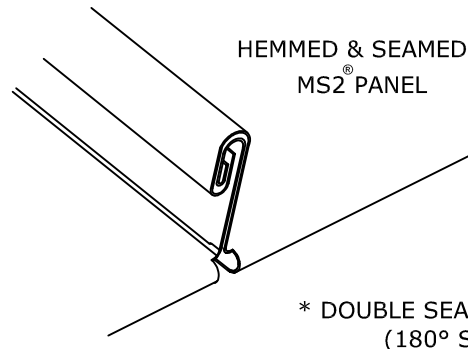

* DOUBLE SEAM UL RATED
(180° SEAM)

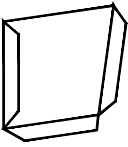
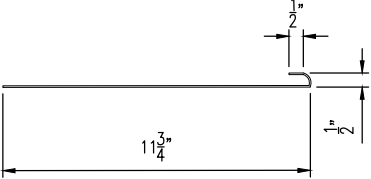
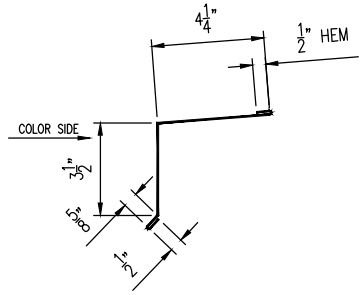
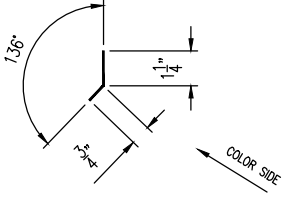
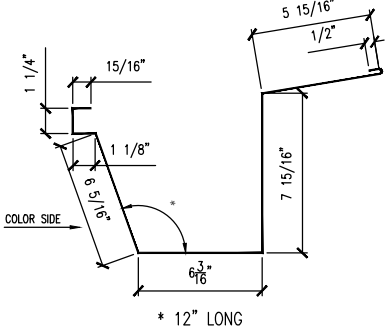
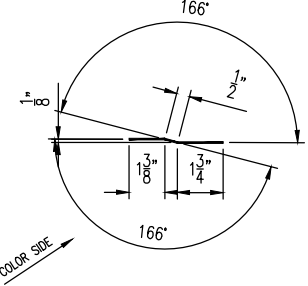
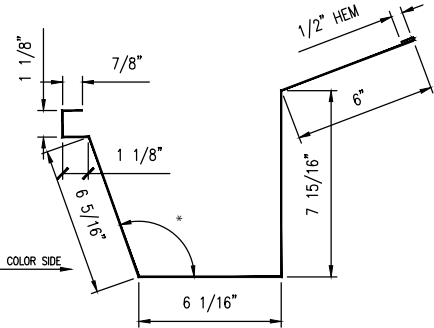
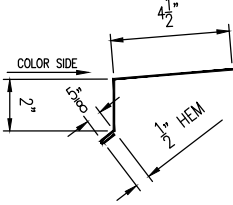
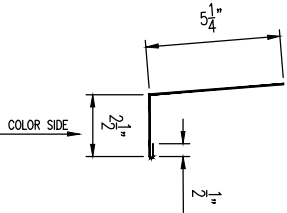
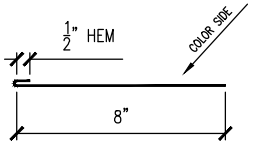
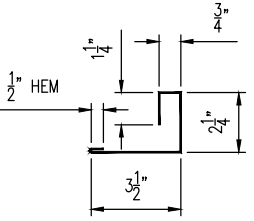
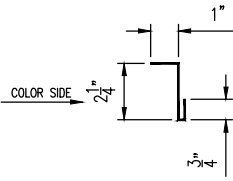
| | | | |
|---|---|---|--|
| <p>GUTTER END CAP WS-100</p>  | <p>16 GA. BACKUP PLATE WS-101</p>  | <p>EAVE FLASHING WS-102</p>  | <p>PANEL CLEAT WS-103</p>  |
| <p>GUTTER SPLICE WS-104</p>  <p>* 12" LONG</p> | <p>JOGGLE CLEAT WS-105</p>  | <p>GUTTER WS-106</p>  | <p>OPTIONAL EAVE TRIM WS-107</p>  |
| <p>OPTIONAL EAVE FLASH WS-108</p>  | <p>GUTTER STRAP WS-109</p>  | <p>18 GA. PANEL RECEIVER WS-110</p>  | <p>ANGLE TRIM WS-111</p>  |

Western States Metal Roofing

901 W. Watkins St.
 Phoenix, AZ 85007
www.MetalForRoofing.com
www.PaintedRustedRoofing.com
www.MetalDeck.com

Phone: (602) 495-0048
 Fax: (602) 261-7726
 877-PURLINS (787-5467)

| | | | |
|-----------------------------------|--|--------------------------|----------|
| STANDARD TRIMS | | | |
| PANEL TYPE: MS2® STANDING SEAM | | A | 04-08-19 |
| | | REV: | DATE: |
| | | DETAIL #: MS2-WSD-ST1 | |

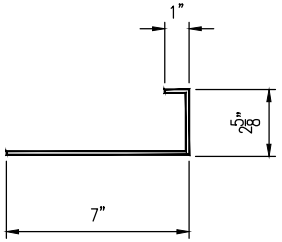
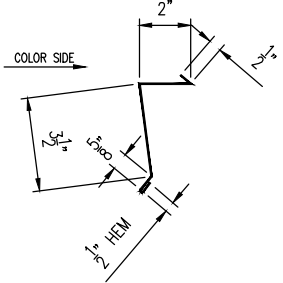
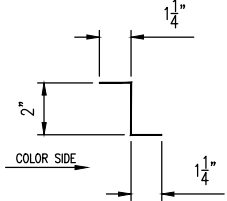
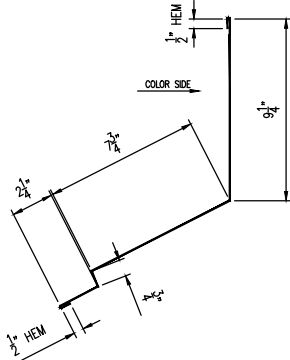
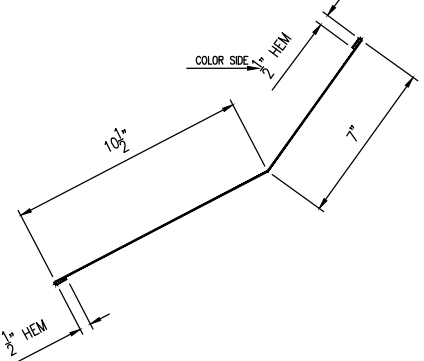
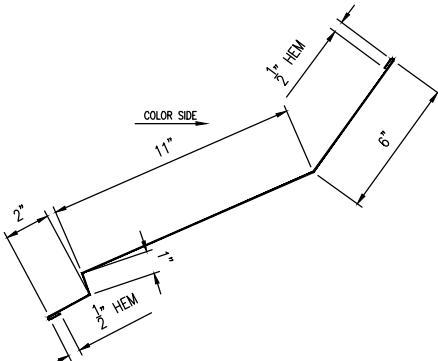
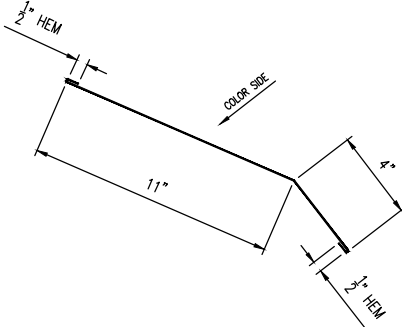
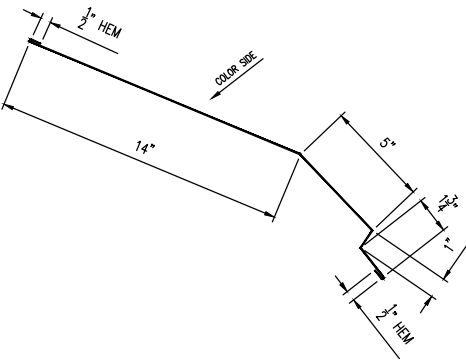
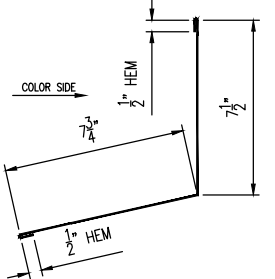
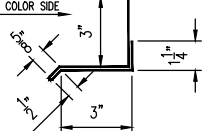
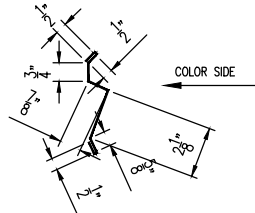
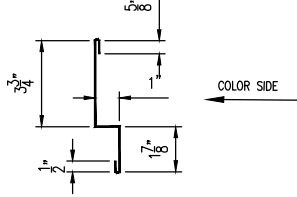
| | | | |
|--|--|---|--|
| <p>18 GA. CONT. PANEL END SUPPORT WS-112</p>  | <p>REGLET FLASHING WS-113</p>  | <p>ZEE CLOSURE WS-114</p>  | <p>HEAD WALL FLASHING WS-115</p>  |
| <p>TRANSITION TRIM WS-116</p>  | <p>TRANSITION TRIM WS-117</p>  | <p>TRANSITION TRIM WS-118</p>  | <p>TRANSITION TRIM WS-119</p>  |
| <p>HEAD WALL FLASHING WS-120</p>  | <p>SILL TRIM WS-121</p>  | <p>REGLET FLASHING WS-122</p>  | <p>RAKE WALL TRIM WS-123</p>  |

Western States Metal Roofing

901 W. Watkins St. Phone: (602) 495-0048
 Phoenix, AZ 85007 Fax: (602) 261-7726
 www.MetalForRoofing.com 877-PURLINS (787-5467)
 www.PaintedRustedRoofing.com
 www.MetalDeck.com

| | | |
|-----------------------------------|------------|--|
| STANDARD TRIM | | |
| PANEL TYPE: MS2® STANDING SEAM | A 04-08-19 | REV: DATE: DETAIL #: MS2-WSD-ST2 |

| | | | |
|---|--------------------------------------|---|--|
| <p>HEAD WALL FLASHING WS-124</p> | <p>HIGH EAVE FLASH WS-125</p> | <p>HIGH EAVE FLASH WS-126</p> | <p>RIDGE/HIP TRIM WS-127</p> |
| <p>RIDGE/HIP TRIM WS-128</p> | <p>VALLEY TRIM WS-129</p> | <p>BULL NOSE DRIP WS-130</p> | <p>REGLET TRIM WS-131</p> |
| <p>VALLEY TRIM WS-132</p> | <p>DOWNSPOUT STRAP WS-133</p> | <p>STRAIGHT DOWNSPOUT WS-134</p> | <p>DOWNSPOUT W/KICKOUT WS-135</p> |

Western States Metal Roofing

901 W. Watkins St.

Phone: (602) 495-0048

Phoenix, AZ 85007

Fax: (602) 261-7726

www.MetalForRoofing.com

877-PURLINS (787-5467)

www.PaintedRustedRoofing.com

www.MetalDeck.com

STANDARD TRIM

PANEL TYPE:

MS2® STANDING SEAM

A 04-08-19

REV: DATE:

DETAIL #:

MS2-WSD-ST3

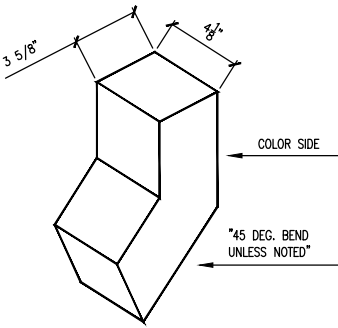
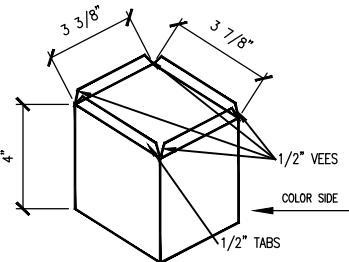
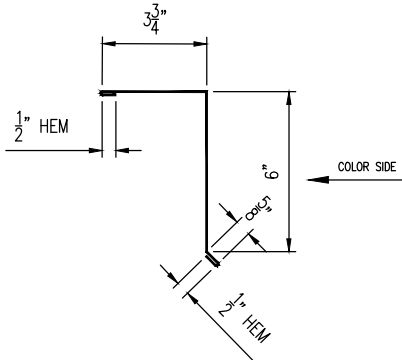
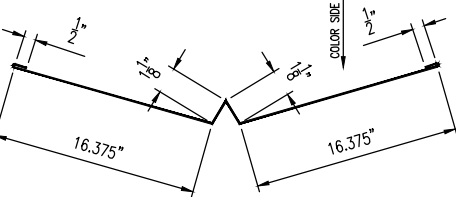
| DOWNSPOUT ELBOW WS-136 | DOWNSPOUT OUTLET WS-137 | GABLE TRIM WS-138 | VALLEY TRIM WS-139 |
|--|--|---|---|
|  <p>3 5/8"</p> <p>3/8"</p> <p>COLOR SIDE</p> <p>*45 DEG. BEND UNLESS NOTED*</p> |  <p>3 3/8"</p> <p>3 7/8"</p> <p>4"</p> <p>1/2" VEEES</p> <p>1/2" TABS</p> <p>COLOR SIDE</p> |  <p>3 3/4"</p> <p>1/2" HEM</p> <p>6"</p> <p>COLOR SIDE</p> <p>1/2" HEM</p> |  <p>16.375"</p> <p>16.375"</p> <p>COLOR SIDE</p> |
| | | | |
| | | | |
| | | | |

Western States Metal Roofing

901 W. Watkins St.
 Phoenix, AZ 85007
www.MetalForRoofing.com
www.PaintedRustedRoofing.com
www.MetalDeck.com

Phone: (602) 495-0048
 Fax: (602) 261-7726
 877-PURLINS (787-5467)

STANDARD TRIM

PANEL TYPE:
 MS2® STANDING SEAM

| | |
|-------------|----------|
| | |
| A | 04-08-19 |
| REV: | DATE: |
| DETAIL #: | |
| MS2-WSD-ST4 | |

Western States "MS-2® Standing Seam"

Installation, Flashings & Shop Drawing Detail Guide

For maximum holding power, it is recommended that the minimum wood penetration be 1 inch. Using pancake head screw fasteners that are designed to be used with fastening clips to the metal roofing panels.

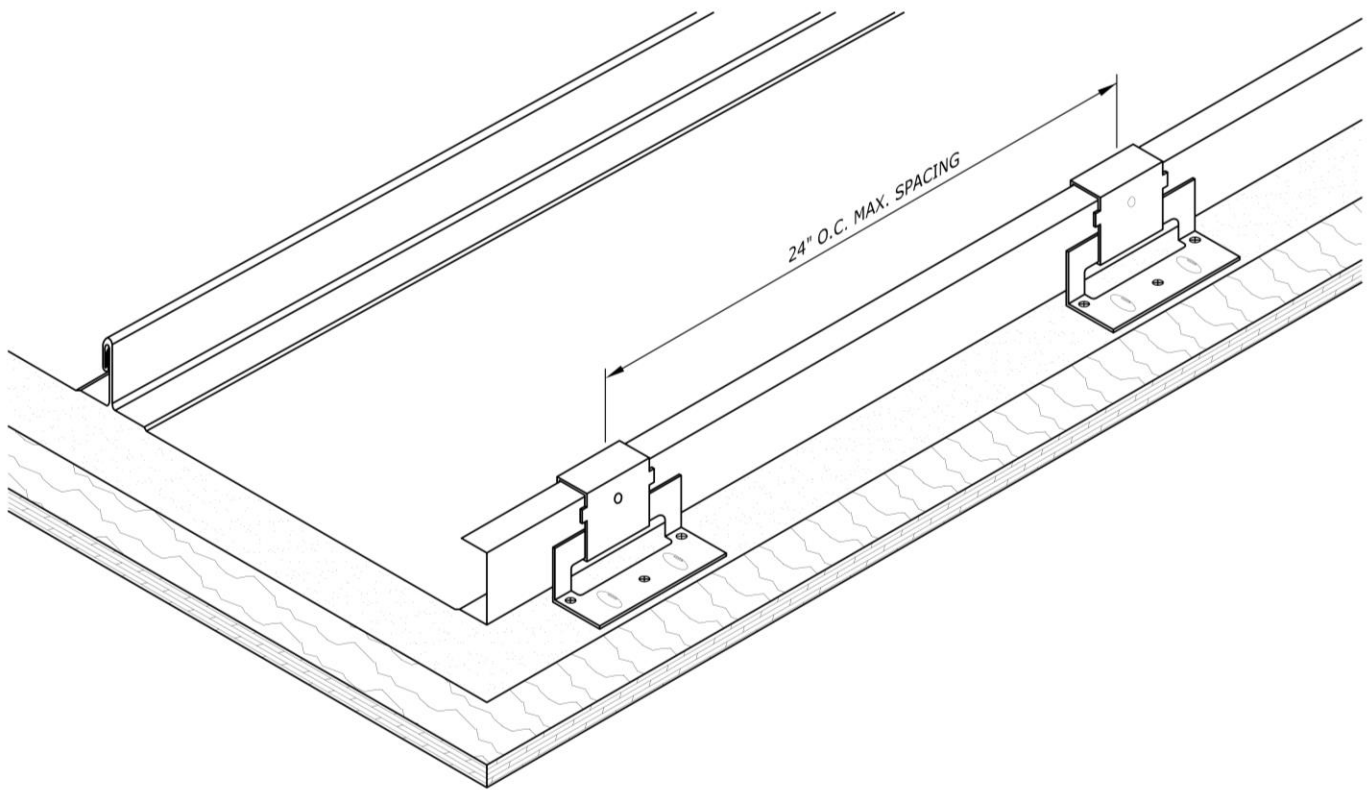

WSMR will not be responsible for final screw/clip selection. This guide is just a reference tool to be used. Please consult a design engineer for load and design calculations.

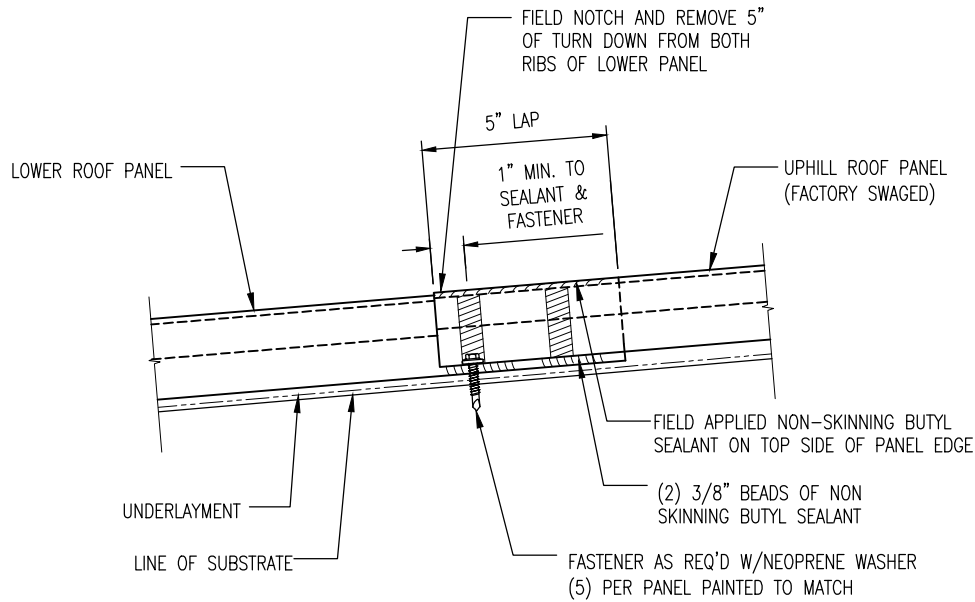

INSTALLATION NOTES:

- SWAGE TOP PANEL ONLY
- PANEL MUST BE INSTALLED LEFT TO RIGHT ONLY
- END LAPS OF ADJACENT PANELS MUST BE STAGGERED AT LEAST ONE PURLINE OR A MINIMUM OF 24" TO PREVENT MATERIAL BUILD-UP AT LAPS

| | |
|-----------------|---------------|
| GAUGE: _____ | COLOR: _____ |
| LENGTH: _____ | FINISH: _____ |
| MATERIAL: _____ | |

Western States Metal Roofing

901 W. Watkins St.

Phone: (602) 495-0048

Phoenix, AZ 85007

Fax: (602) 261-7726

www.MetalForRoofing.com

877-PURLINS (787-5467)

www.PaintedRustedRoofing.com

www.MetalDeck.com

| | | |
|---|-------------------------|----------|
| FIXED LAP DETAIL | | |
| | A | 04-08-19 |
| PANEL TYPE: MS2 [®] STANDING SEAM | REV: | DATE: |
| | DETAIL #: MS2-WSD-S1 | |

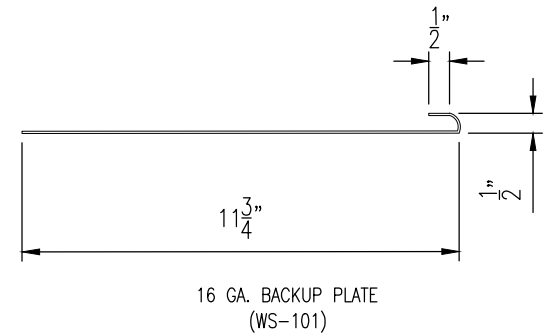
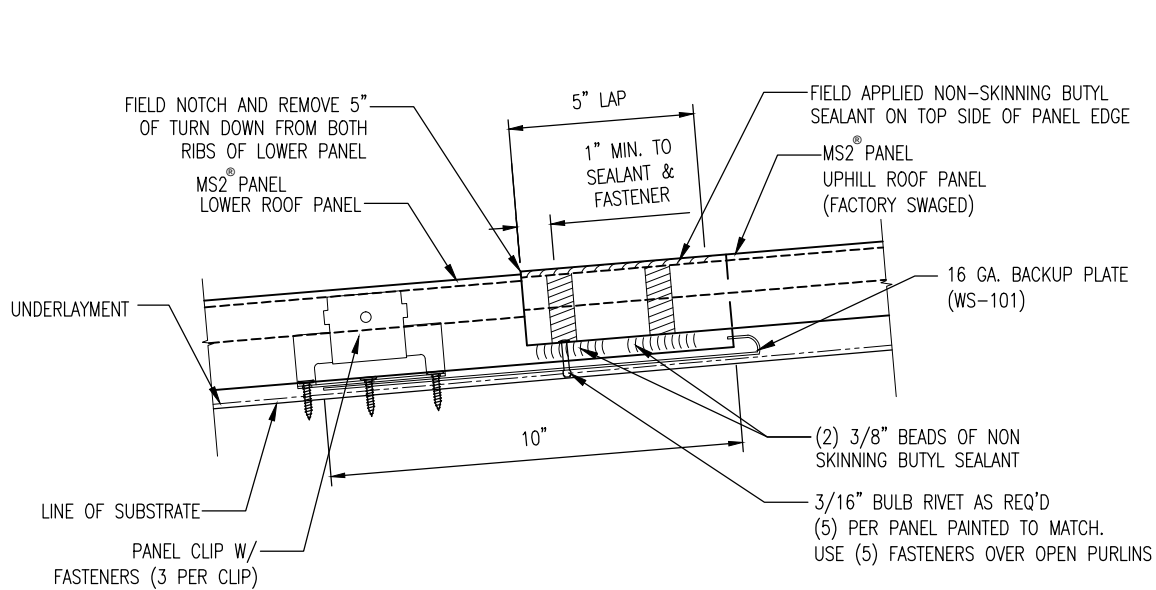

INSTALLATION NOTES:

- SWAGE TOP PANEL ONLY
- PANEL MUST BE INSTALLED LEFT TO RIGHT ONLY
- END LAPS OF ADJACENT PANELS MUST BE STAGGERED AT LEAST ONE PURLIN OR A MINIMUM OF 24" TO PREVENT MATERIAL BUILD-UP AT LAPS

| | |
|-----------------|---------------|
| GAUGE: _____ | COLOR: _____ |
| LENGTH: _____ | FINISH: _____ |
| MATERIAL: _____ | |

Western States Metal Roofing

901 W. Watkins St.
 Phoenix, AZ 85007
www.MetalForRoofing.com
www.PaintedRustedRoofing.com
www.MetalDeck.com

Phone: (602) 495-0048
 Fax: (602) 261-7726
 877-PURLINS (787-5467)

| | | |
|-----------------------------------|--------------------------|----------|
| FLOATING LAP DETAIL | | |
| | A | 04-08-19 |
| PANEL TYPE: MS2® STANDING SEAM | REV: | DATE: |
| | DETAIL #: MS2-WSD-SW2 | |

Western States "MS-2"® Standing Seam

Installation, Flashings & Shop Drawing Detail Guide

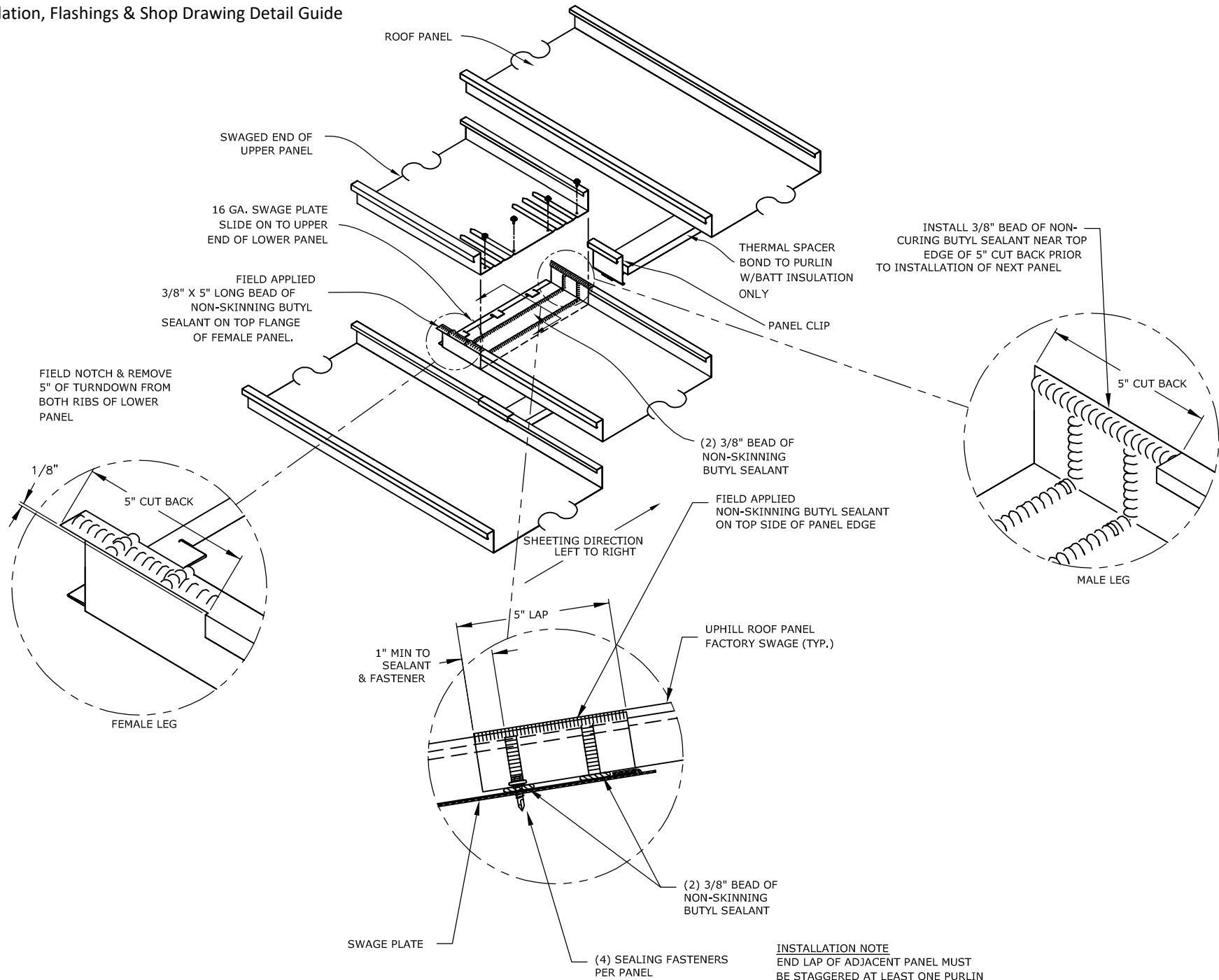

INSTALLATION NOTE
 END LAP OF ADJACENT PANEL MUST BE STAGGERED AT LEAST ONE PURLIN SPACING OR A MIN. 24" TO PREVENT MATERIAL BUILDUP AT LAPS

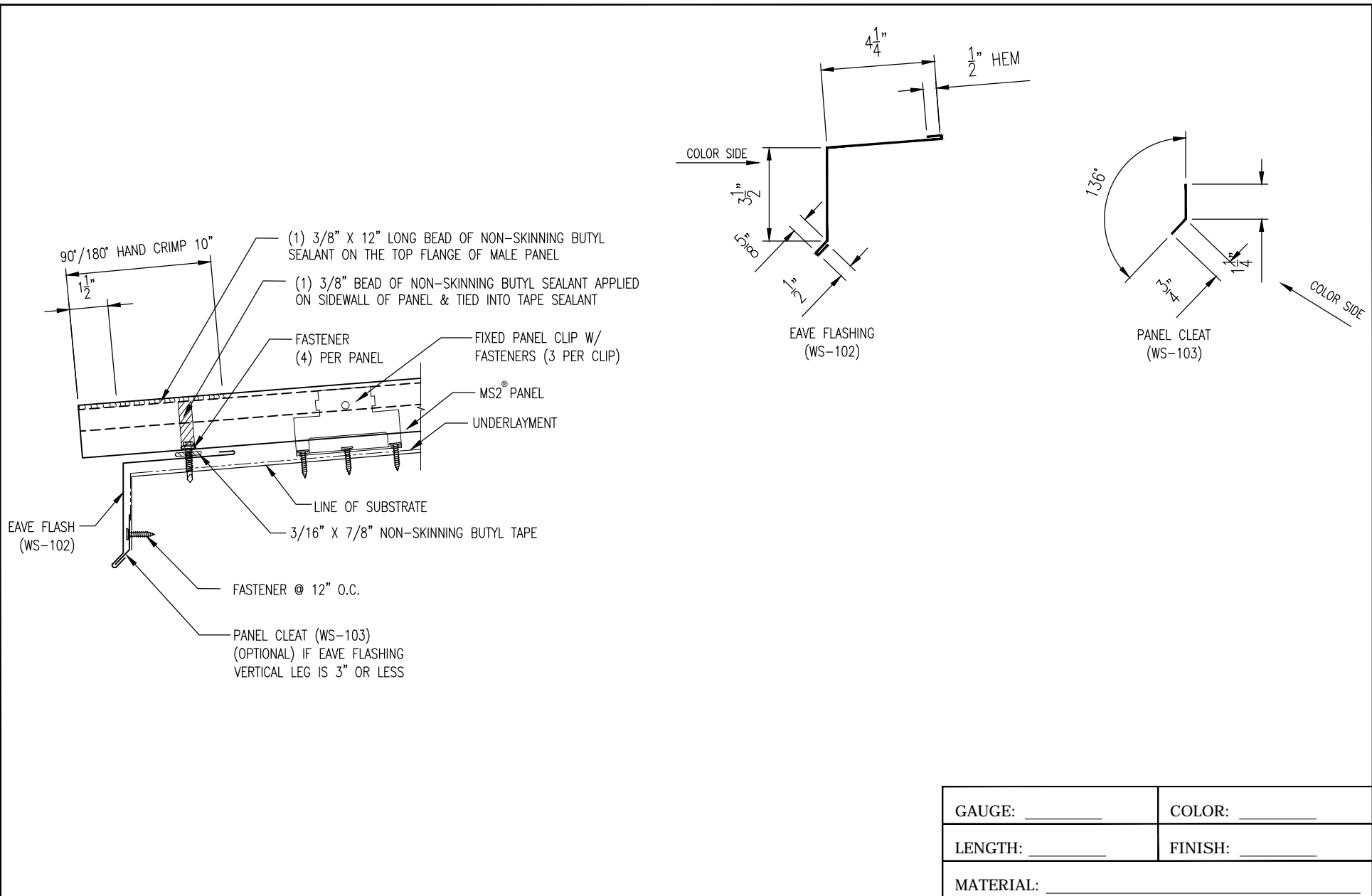

| | |
|-----------------|---------------|
| GAUGE: _____ | COLOR: _____ |
| LENGTH: _____ | FINISH: _____ |
| MATERIAL: _____ | |

Western States Metal Roofing

901 W. Watkins St. Phone: (602) 495-0048
 Phoenix, AZ 85007 Fax: (602) 261-7726
 www.MetalForRoofing.com 877-PURLINS (787-5467)
 www.PaintedRustedRoofing.com
 www.MetalDeck.com

| | | |
|-----------------------------------|-------------------------|----------|
| FIXED EAVE DETAIL | | |
| | A | 04-08-19 |
| PANEL TYPE: MS2® STANDING SEAM | REV: | DATE: |
| | DETAIL #: MS2-WSD-S3 | |

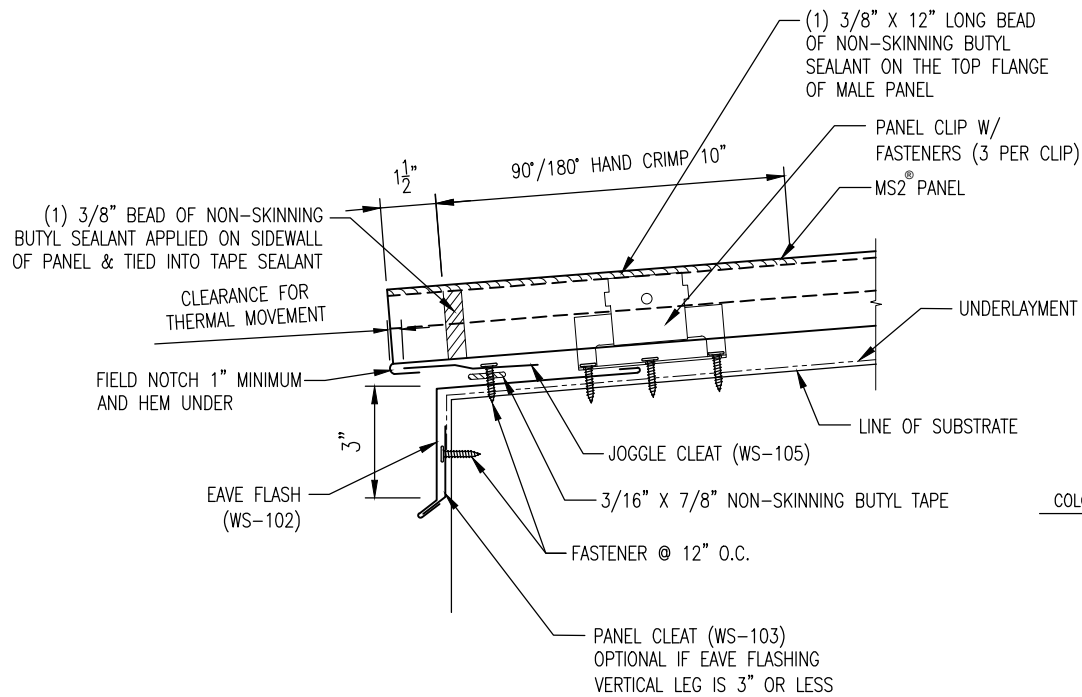

* 6" MAX CLIP PLACEMENT FROM END OF PANEL

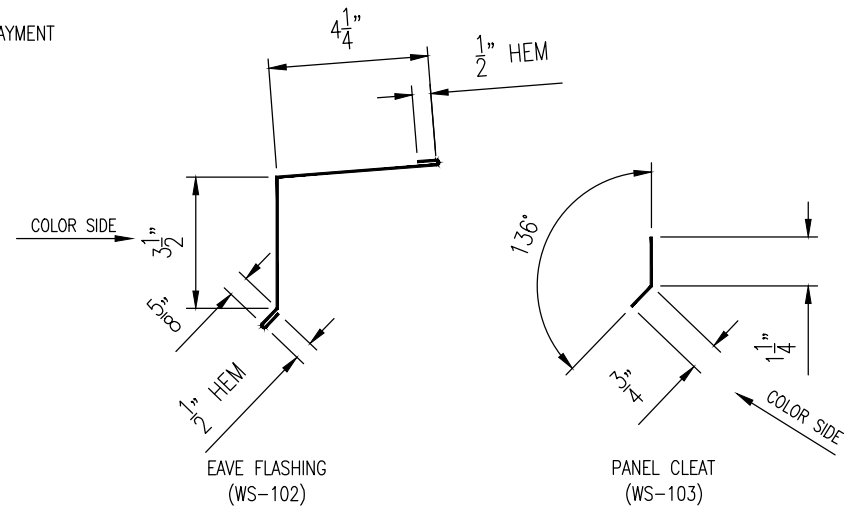
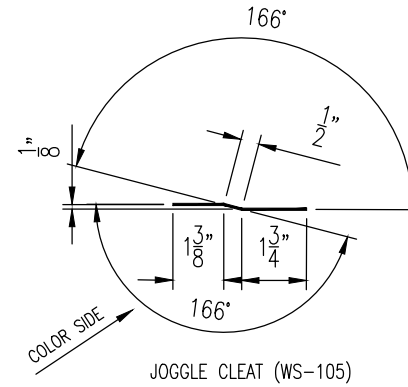

| | |
|-----------------|---------------|
| GAUGE: _____ | COLOR: _____ |
| LENGTH: _____ | FINISH: _____ |
| MATERIAL: _____ | |

Western States Metal Roofing

901 W. Watkins St.
 Phoenix, AZ 85007
 www.MetalForRoofing.com
 www.PaintedRustedRoofing.com
 www.MetalDeck.com

Phone: (602) 495-0048
 Fax: (602) 261-7726
 877-PURLINS (787-5467)

| | | |
|-----------------------------------|--------------------------|----------|
| FLOATING EAVE DETAIL | | |
| | A | 04-08-19 |
| PANEL TYPE: MS2® STANDING SEAM | REV: | DATE: |
| | DETAIL #: MS2-WSD-SW4 | |

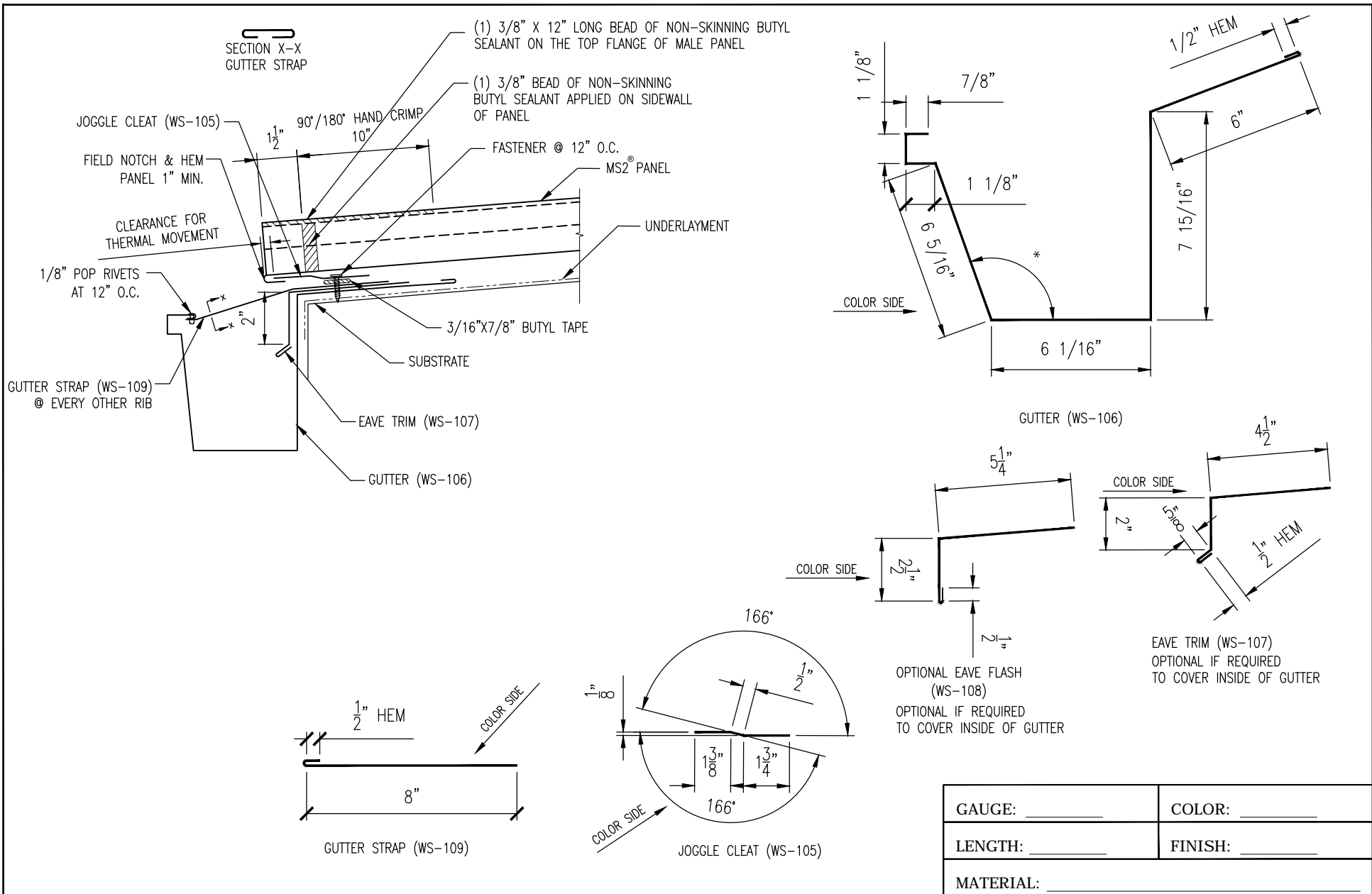

Western States Metal Roofing

901 W. Watkins St.

Phone: (602) 495-0048

Phoenix, AZ 85007

Fax: (602) 261-7726

www.MetalForRoofing.com

877-PURLINS (787-5467)

www.PaintedRustedRoofing.com

www.MetalDeck.com

| | | | |
|-----------------------------------|--|--------------------------|----------|
| GAUGE: _____ | | COLOR: _____ | |
| LENGTH: _____ | | FINISH: _____ | |
| MATERIAL: _____ | | | |
| GUTTER DETAIL | | A | 04-08-19 |
| | | REV: | DATE: |
| PANEL TYPE: MS2® STANDING SEAM | | DETAIL #: MS2-WSD-SW5 | |

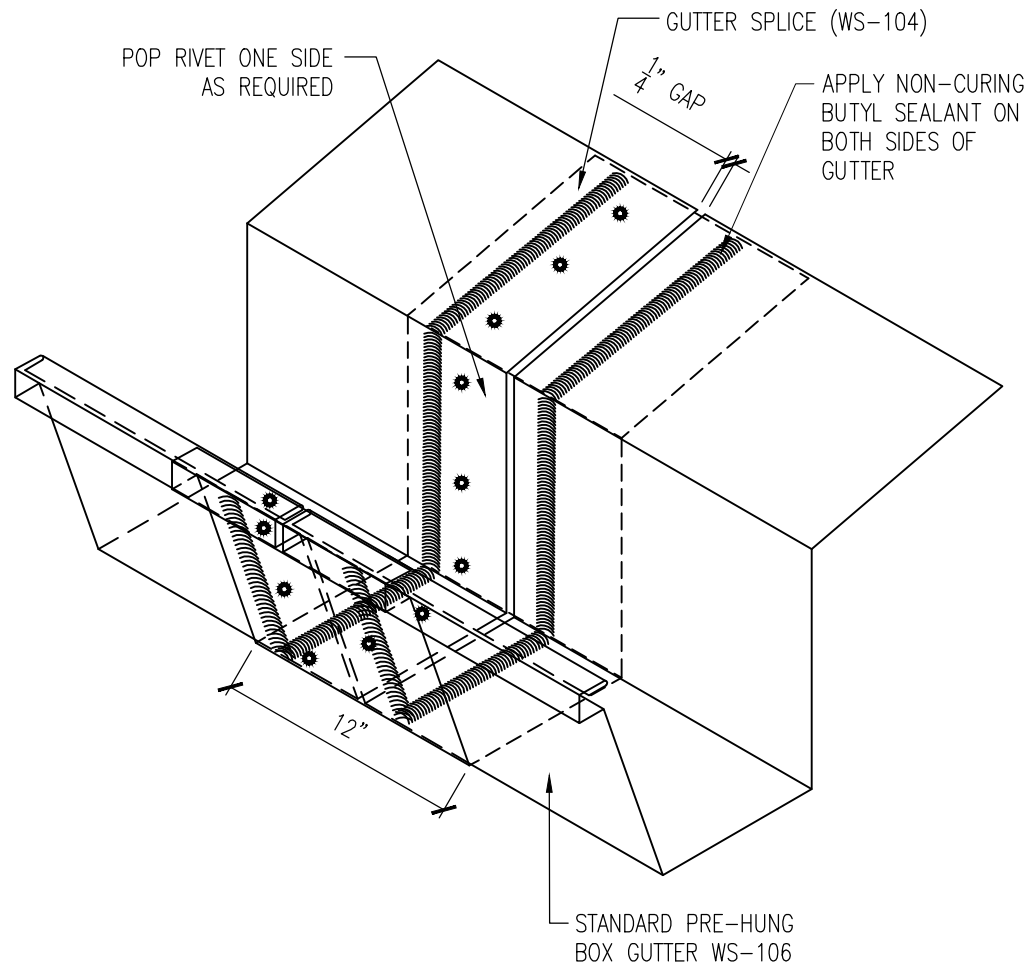

| | |
|-----------------------------------|-------------------------|
| GAUGE: _____ | COLOR: _____ |
| LENGTH: _____ | FINISH: _____ |
| MATERIAL: _____ | |
| GUTTER SPLICE DETAIL | |
| | A 04-08-19 |
| PANEL TYPE: MS2® STANDING SEAM | REV: DATE: |
| | DETAIL #: MS2-WSD-GS |

Western States Metal Roofing

901 W. Watkins St.

Phone: (602) 495-0048

Phoenix, AZ 85007

Fax: (602) 261-7726

www.MetalForRoofing.com

877-PURLINS (787-5467)

www.PaintedRustedRoofing.com

www.MetalDeck.com

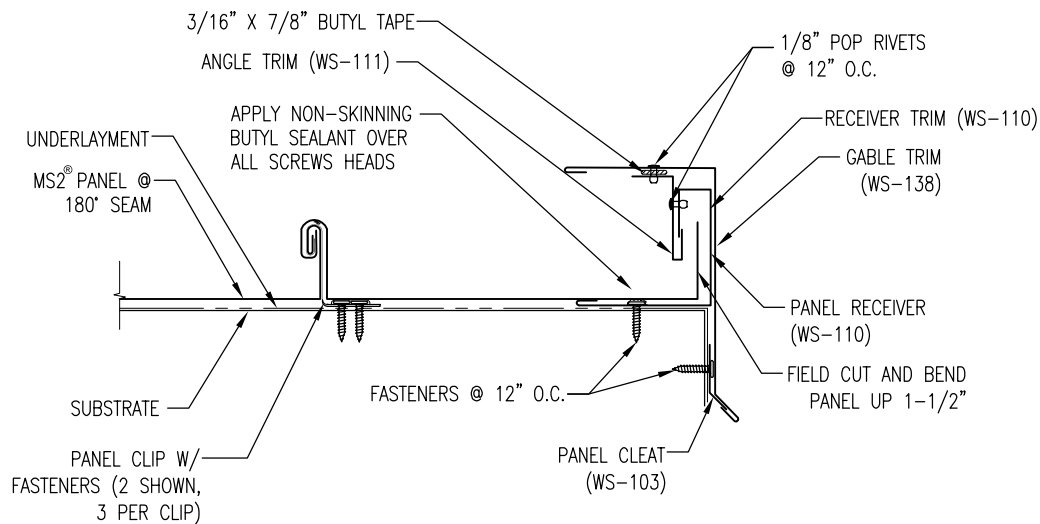

NOTE:
FIELD CUT FIRST AND
LAST PANELS TO EQUAL WIDTH

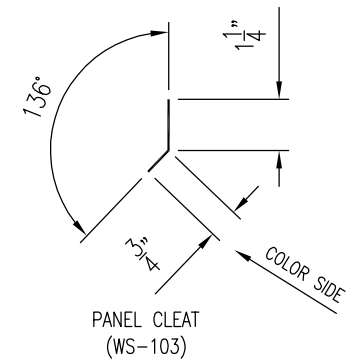
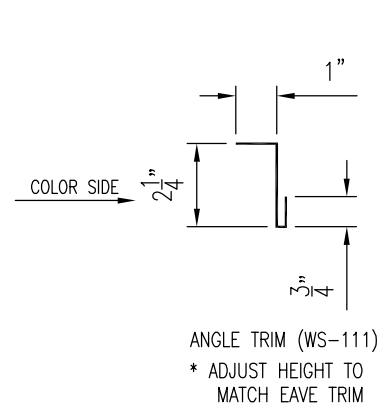
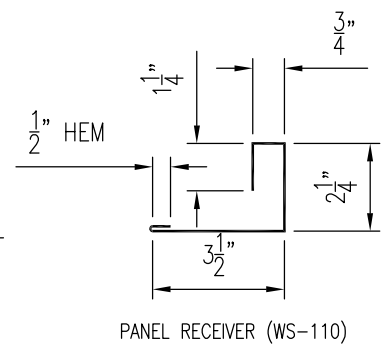
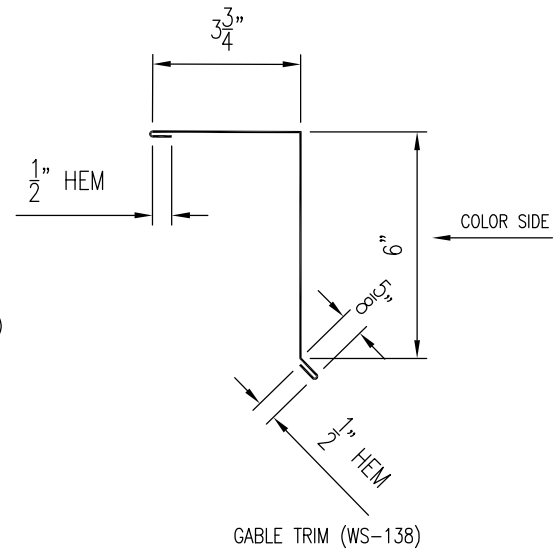

| | | | |
|-----------------------------------|--|---------------|-------------------------|
| GAUGE: _____ | | COLOR: _____ | |
| LENGTH: _____ | | FINISH: _____ | |
| MATERIAL: _____ | | | |
| RAKE DETAIL (180° SEAM) | | | |
| | | | A 04-08-19 |
| PANEL TYPE: MS2® STANDING SEAM | | | REV: DATE: |
| | | | DETAIL #: MS2-WSD-W6 |

Western States Metal Roofing

901 W. Watkins St.
Phoenix, AZ 85007

www.MetalForRoofing.com
www.PaintedRustedRoofing.com
www.MetalDeck.com

Phone: (602) 495-0048
Fax: (602) 261-7726
877-PURLINS (787-5467)

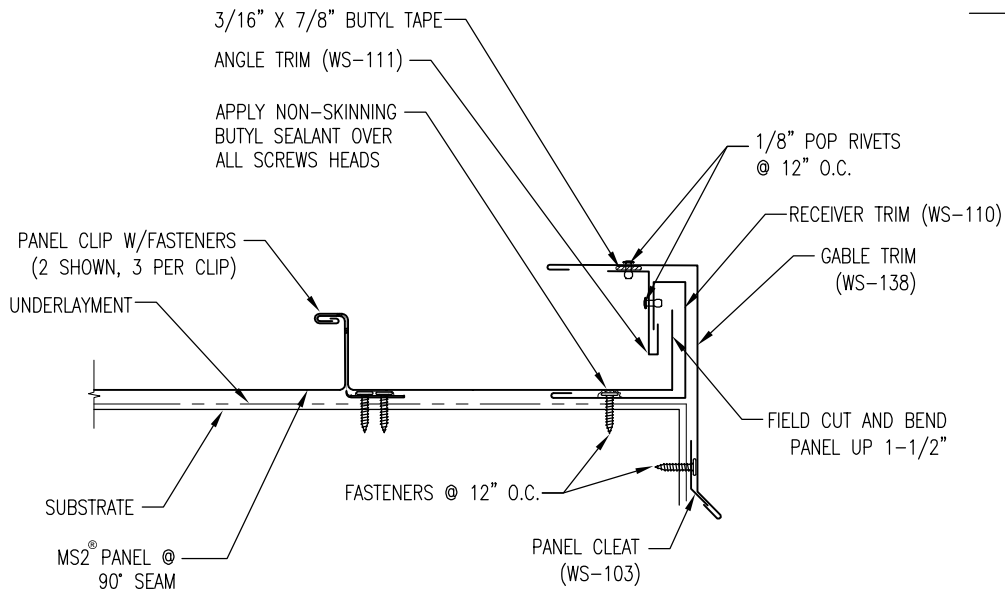

NOTE:
FIELD CUT FIRST AND
LAST PANELS TO EQUAL WIDTH

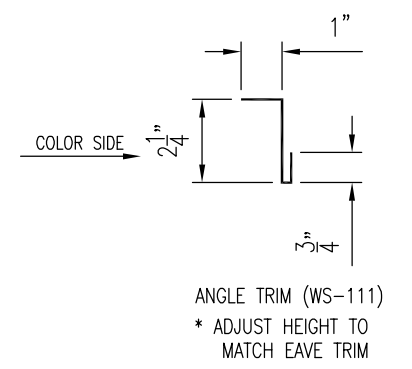
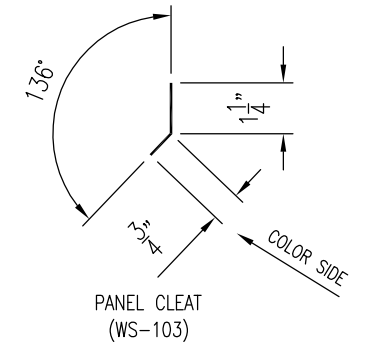
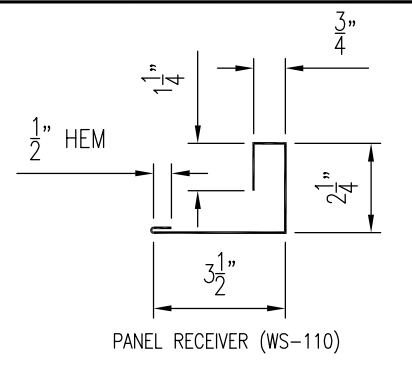
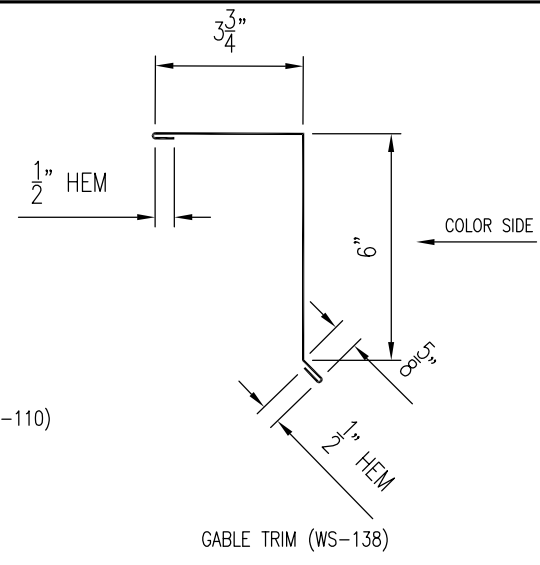

| | |
|-----------------|---------------|
| GAUGE: _____ | COLOR: _____ |
| LENGTH: _____ | FINISH: _____ |
| MATERIAL: _____ | |

Western States Metal Roofing

901 W. Watkins St. Phone: (602) 495-0048
 Phoenix, AZ 85007 Fax: (602) 261-7726
 www.MetalForRoofing.com 877-PURLINS (787-5467)
 www.PaintedRustedRoofing.com
 www.MetalDeck.com

| | | |
|-----------------------------------|-----------|-------------|
| RAKE DETAIL (90° SEAM) | | |
| | A | 04-08-19 |
| PANEL TYPE: MS2® STANDING SEAM | REV: | DATE: |
| | DETAIL #: | MS2-WSD-SW7 |

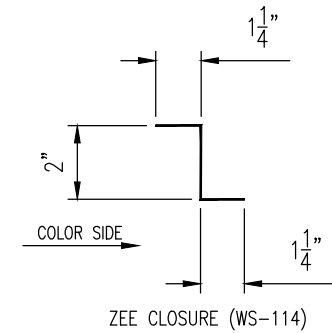
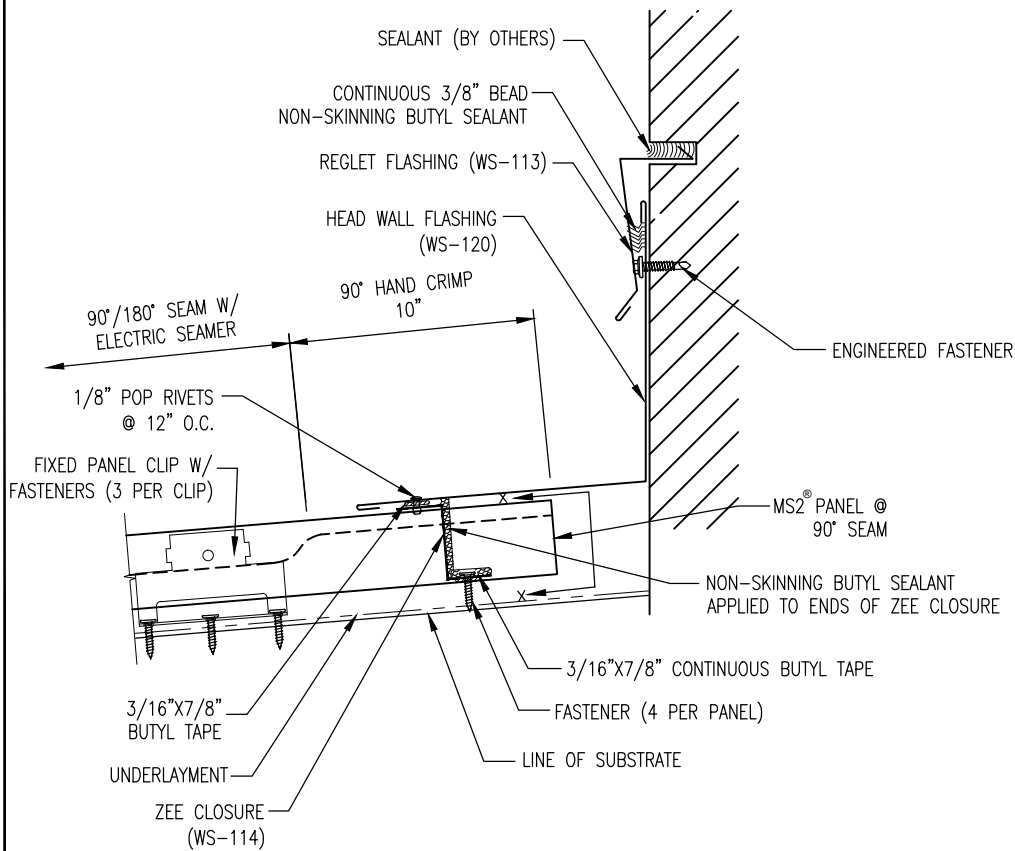
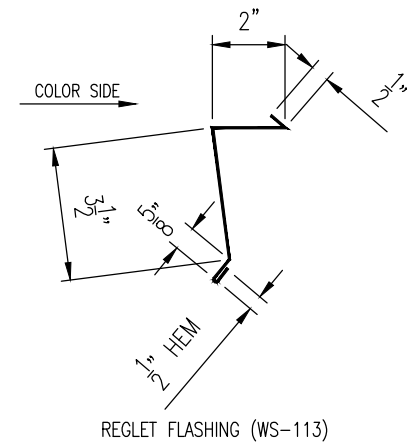
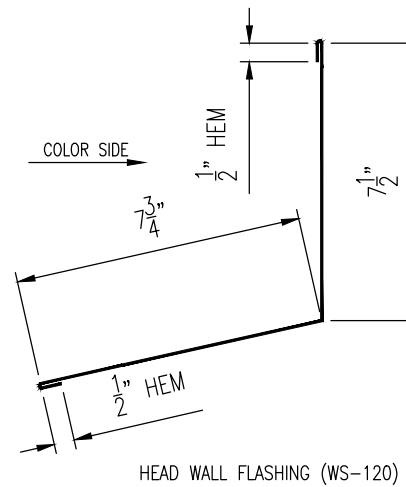
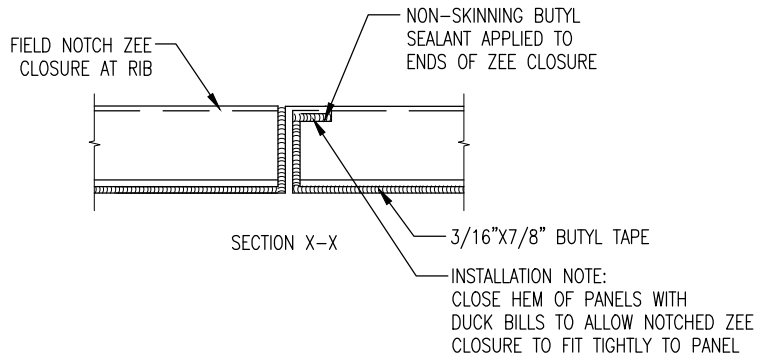

| | |
|--------------------------|---------------|
| GAUGE: _____ | COLOR: _____ |
| LENGTH: _____ | FINISH: _____ |
| MATERIAL: _____ | |
| HEAD WALL DETAIL (FIXED) | |
| A | 04-08-19 |
| PANEL TYPE: | REV: DATE: |
| MS2® STANDING SEAM | DETAIL #: |
| | MS2-WSD-SW8 |

Western States Metal Roofing

901 W. Watkins St.
Phoenix, AZ 85007
www.MetalForRoofing.com
www.PaintedRustedRoofing.com
www.MetalDeck.com

Phone: (602) 495-0048
Fax: (602) 261-7726
877-PURLINS (787-5467)

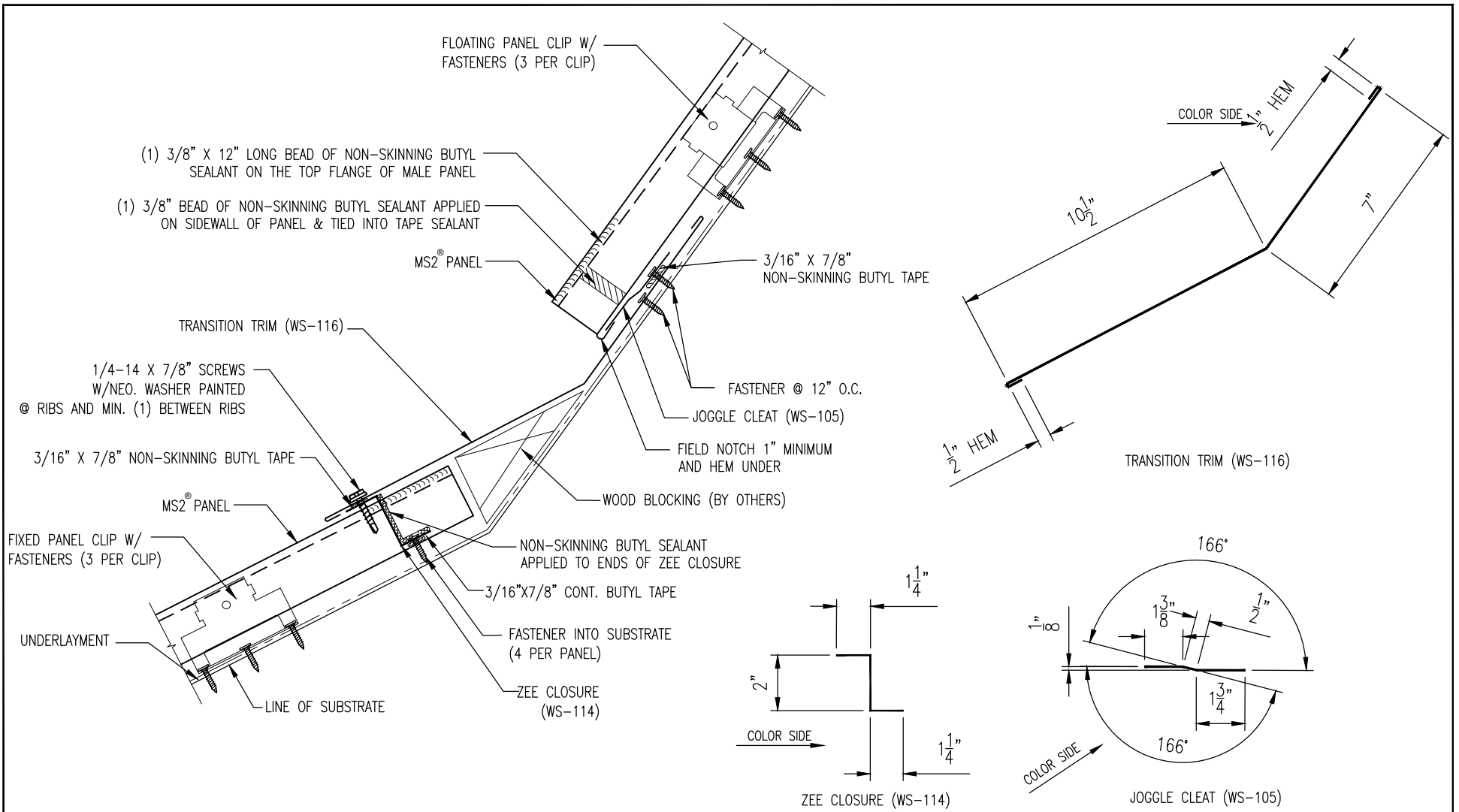

| | | | |
|-----------------------------------|---------------|--------------------------|----------|
| GAUGE: _____ | COLOR: _____ | | |
| LENGTH: _____ | FINISH: _____ | | |
| MATERIAL: _____ | | | |
| L/H PITCHBREAK DETAIL (FIXED) | | A | 04-08-19 |
| | | REV: | DATE: |
| PANEL TYPE: MS2® STANDING SEAM | | DETAIL #: MS2-WSD-W10 | |

Western States Metal Roofing

901 W. Watkins St.

Phone: (602) 495-0048

Phoenix, AZ 85007

Fax: (602) 261-7726

www.MetalForRoofing.com

877-PURLINS (787-5467)

www.PaintedRustedRoofing.com

www.MetalDeck.com

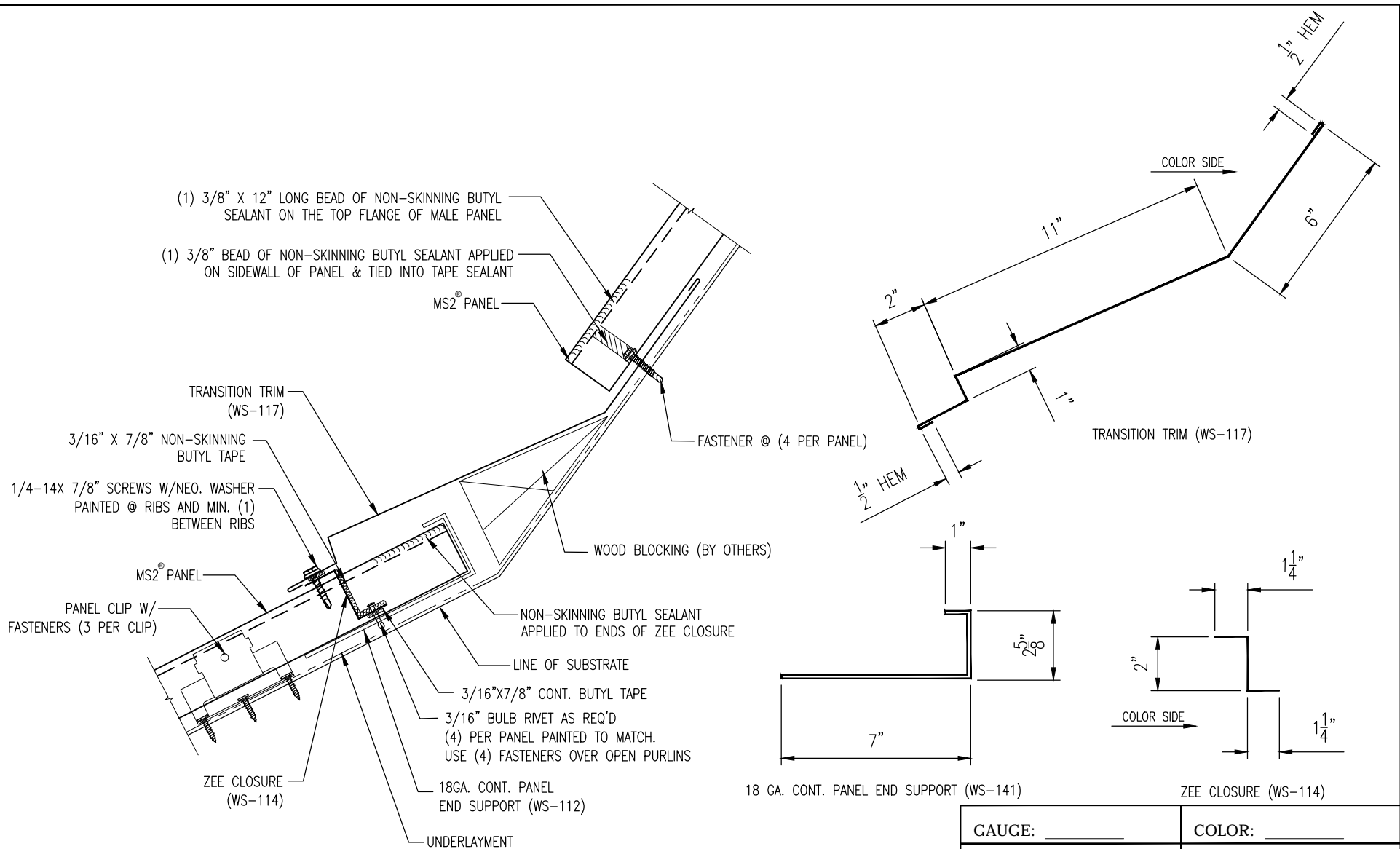

| | |
|-----------------|---------------|
| GAUGE: _____ | COLOR: _____ |
| LENGTH: _____ | FINISH: _____ |
| MATERIAL: _____ | |

| | | |
|-------------------------------------|--------------------------|----------|
| L/H PITCHBREAK DETAIL (FLOATING) | | |
| | A | 04-08-19 |
| PANEL TYPE: MS2® STANDING SEAM | REV: | DATE: |
| | DETAIL #: MS2-WSD-W11 | |

Western States Metal Roofing

901 W. Watkins St. Phone: (602) 495-0048
 Phoenix, AZ 85007 Fax: (602) 261-7726
 www.MetalForRoofing.com 877-PURLINS (787-5467)
 www.PaintedRustedRoofing.com
 www.MetalDeck.com

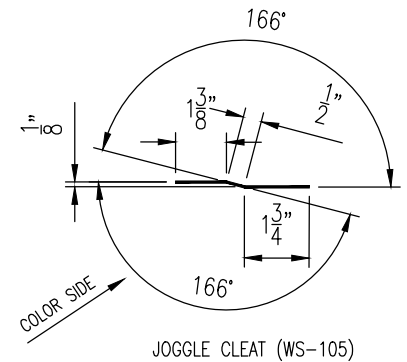
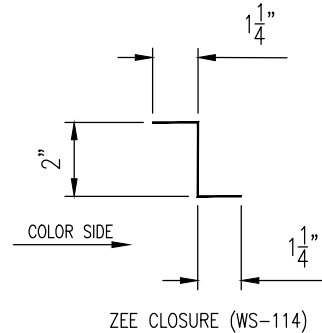
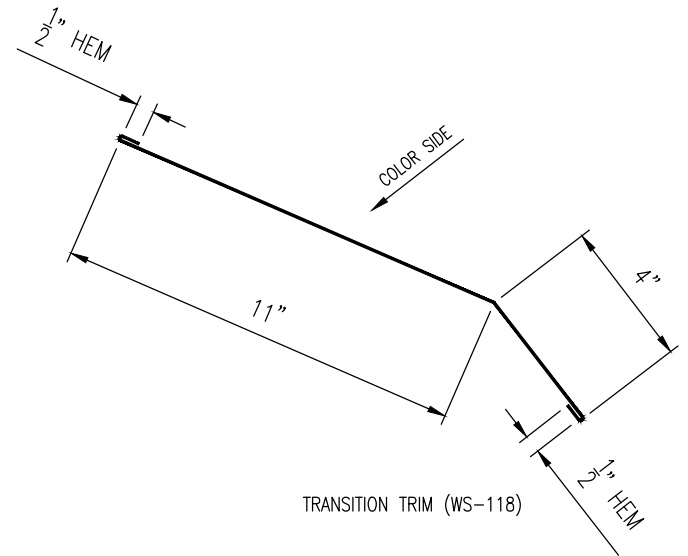
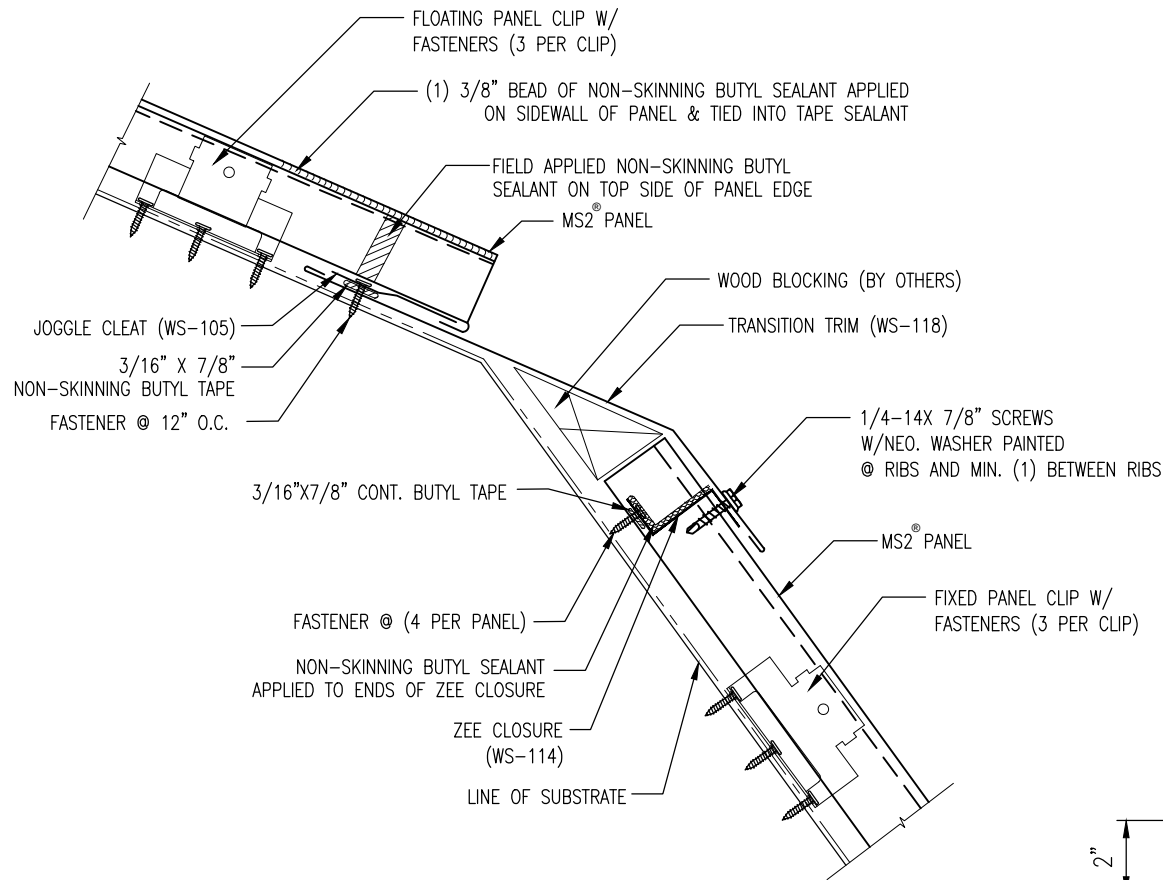

| | |
|-----------------|---------------|
| GAUGE: _____ | COLOR: _____ |
| LENGTH: _____ | FINISH: _____ |
| MATERIAL: _____ | |

Western States Metal Roofing

901 W. Watkins St.

Phone: (602) 495-0048

Phoenix, AZ 85007

Fax: (602) 261-7726

www.MetalForRoofing.com

877-PURLINS (787-5467)

www.PaintedRustedRoofing.com

www.MetalDeck.com

H/L PITCHBREAK DETAIL
(FIXED)

A 04-08-19

PANEL TYPE:

MS2® STANDING SEAM

REV: DATE:

DETAIL #:
MS2-WSD-W12

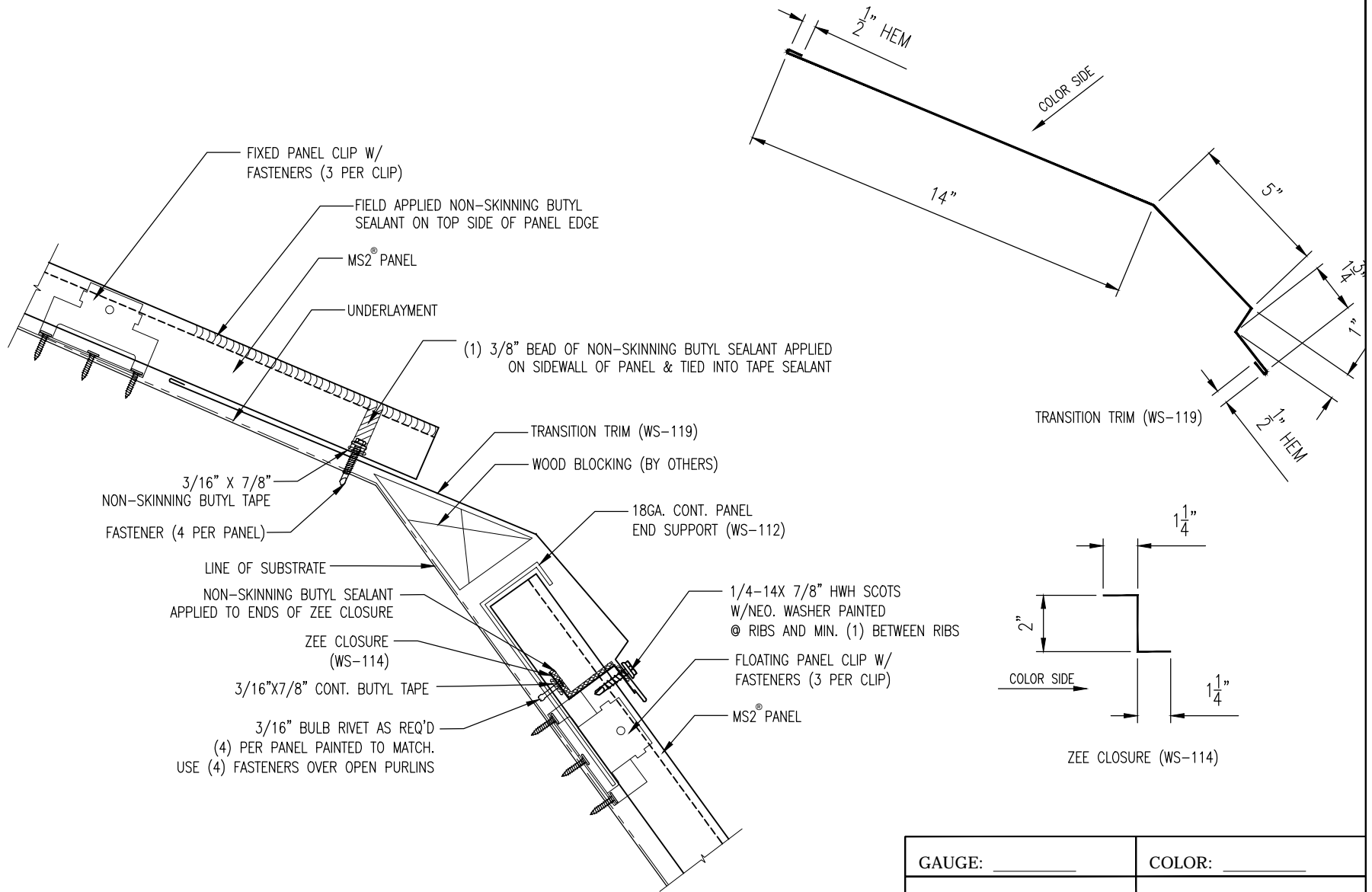

| | |
|-----------------|---------------|
| GAUGE: _____ | COLOR: _____ |
| LENGTH: _____ | FINISH: _____ |
| MATERIAL: _____ | |

Western States Metal Roofing

901 W. Watkins St.

Phoenix, AZ 85007

www.MetalForRoofing.com

www.PaintedRustedRoofing.com

www.MetalDeck.com

Phone: (602) 495-0048

Fax: (602) 261-7726

877-PURLINS (787-5467)

| | | |
|-------------------------------------|--------------------------|----------|
| H/L PITCHBREAK DETAIL (FLOATING) | | |
| | A | 04-08-19 |
| PANEL TYPE: MS2® STANDING SEAM | REV: | DATE: |
| | DETAIL #: MS2-WSD-W13 | |

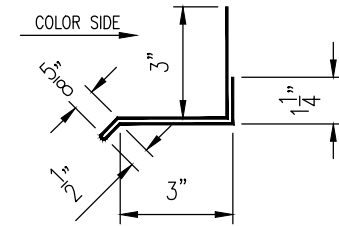
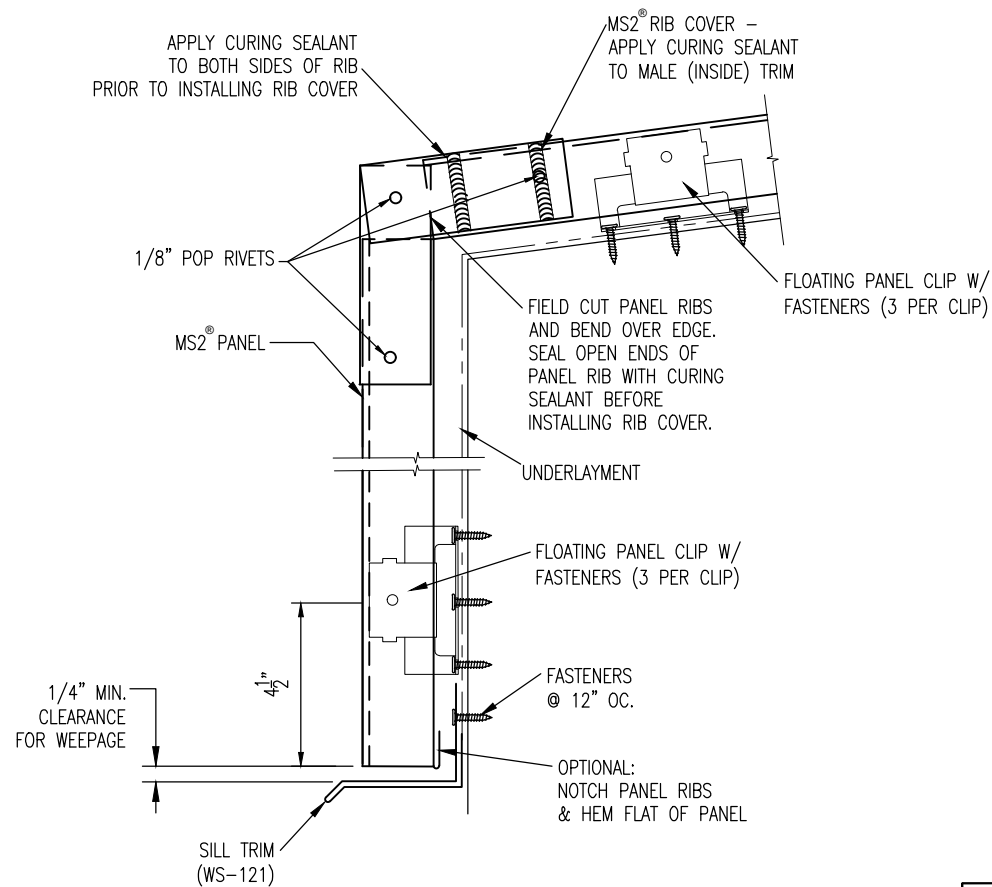

SILL TRIM (WS-121)

| | |
|-----------------|---------------|
| GAUGE: _____ | COLOR: _____ |
| LENGTH: _____ | FINISH: _____ |
| MATERIAL: _____ | |

Western States Metal Roofing

901 W. Watkins St.

Phone: (602) 495-0048

Phoenix, AZ 85007

Fax: (602) 261-7726

www.MetalForRoofing.com

877-PURLINS (787-5467)

www.PaintedRustedRoofing.com

www.MetalDeck.com

| | | |
|-----------------------------------|--------------------------|----------|
| RIB COVER DETAIL | | |
| | A | 04-08-19 |
| PANEL TYPE: MS2® STANDING SEAM | REV: | DATE: |
| | DETAIL #: MS2-WSD-W14 | |

Western States "MS-2® Standing Seam" Panel

Installation, Flashings & Shop Drawing Detail Guide

MS-2 RIB COVER

DESIGN CAUTION:
ROOF SLOPE TRANSITIONS
SUCH AS FASCIAS MAY
ESTABLISH AN UNWANTED
POINT OF PANEL FIXITY.

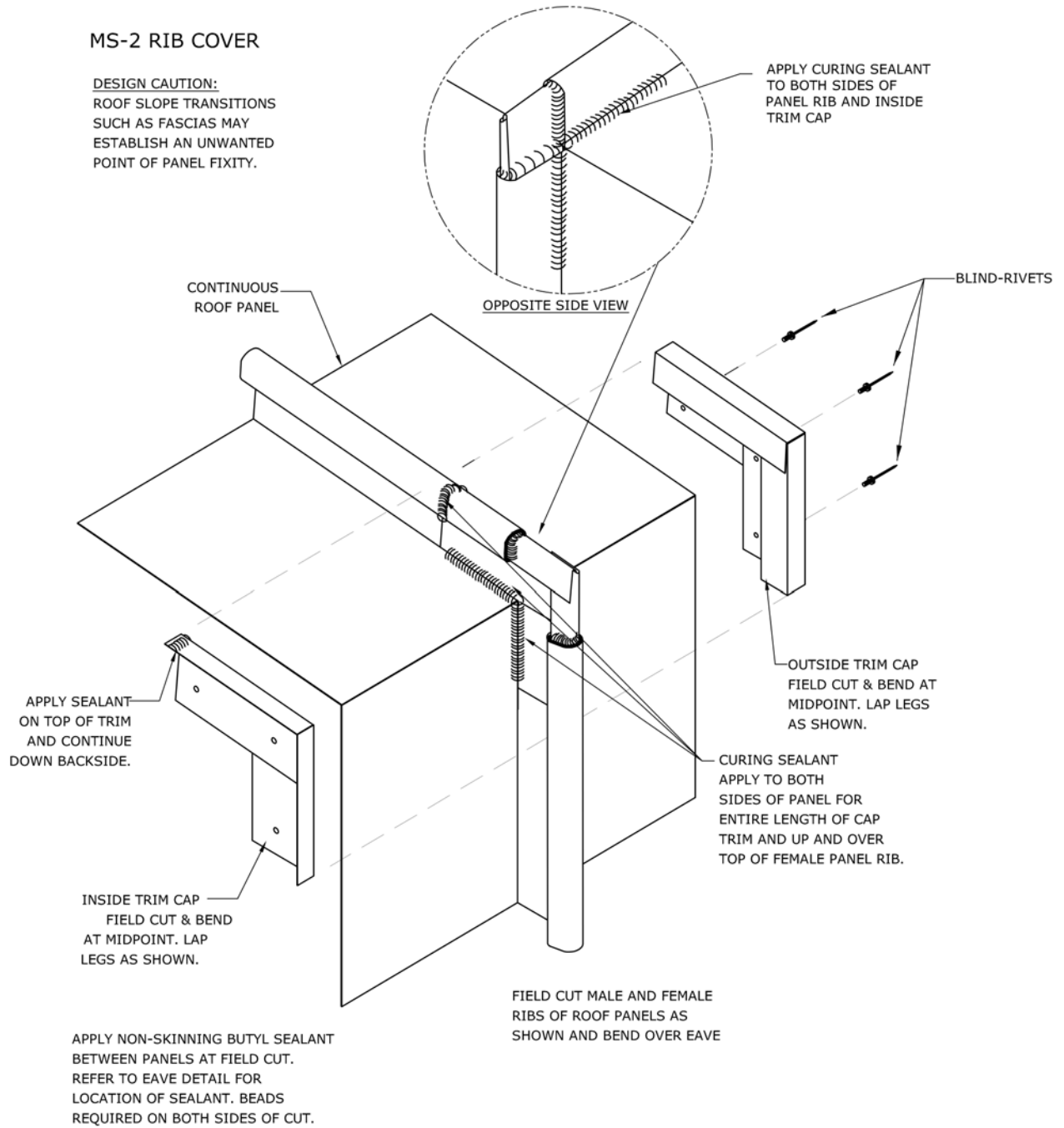

NOTE:
FIELD CUT FIRST
AND LAST
PANELS TO
EQUAL WIDTH.

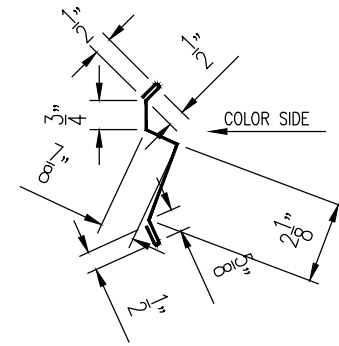
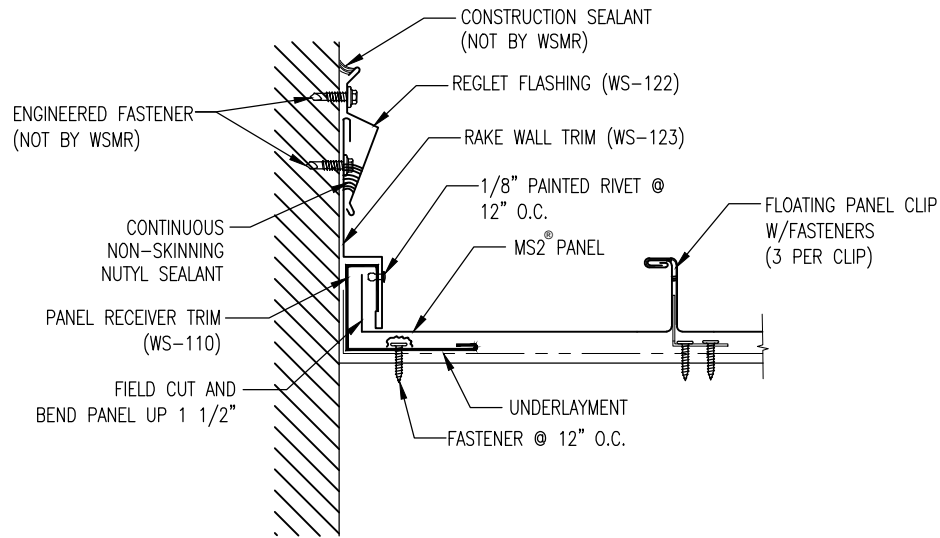

REGLET FLASHING (WS-122)

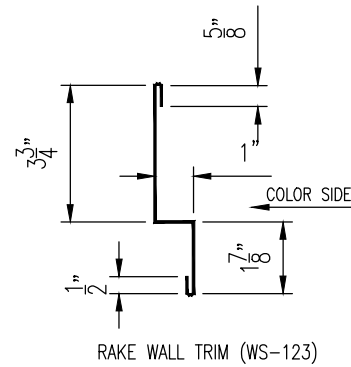

RAKE WALL TRIM (WS-123)

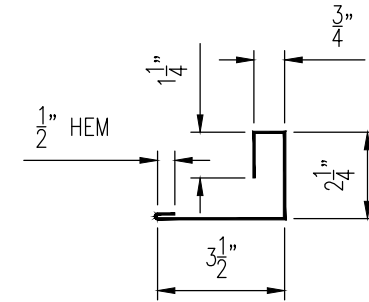

PANEL RECEIVER (WS-110)

| | |
|-----------------|---------------|
| GAUGE: _____ | COLOR: _____ |
| LENGTH: _____ | FINISH: _____ |
| MATERIAL: _____ | |

Western States Metal Roofing

901 W. Watkins St.

Phone: (602) 495-0048

Phoenix, AZ 85007

Fax: (602) 261-7726

www.MetalForRoofing.com

877-PURLINS (787-5467)

www.PaintedRustedRoofing.com

www.MetalDeck.com

| | | |
|-----------------------------------|--------------------------|----------|
| RAKE WALL DETAIL (90° SEAM) | | |
| | A | 04-08-19 |
| PANEL TYPE: MS2® STANDING SEAM | REV: | DATE: |
| | DETAIL #: MS2-WSD-W15 | |

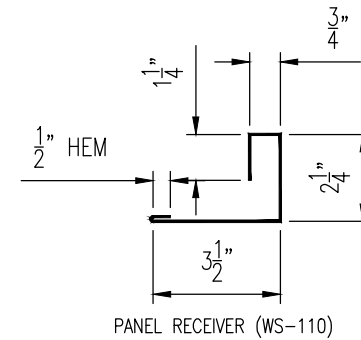
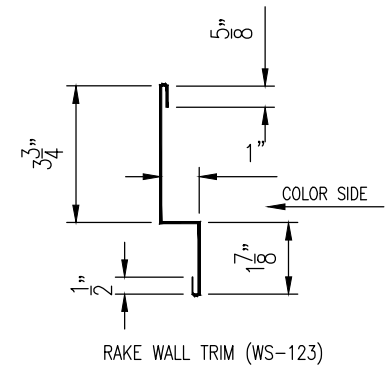
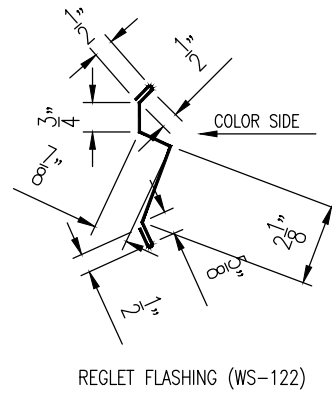
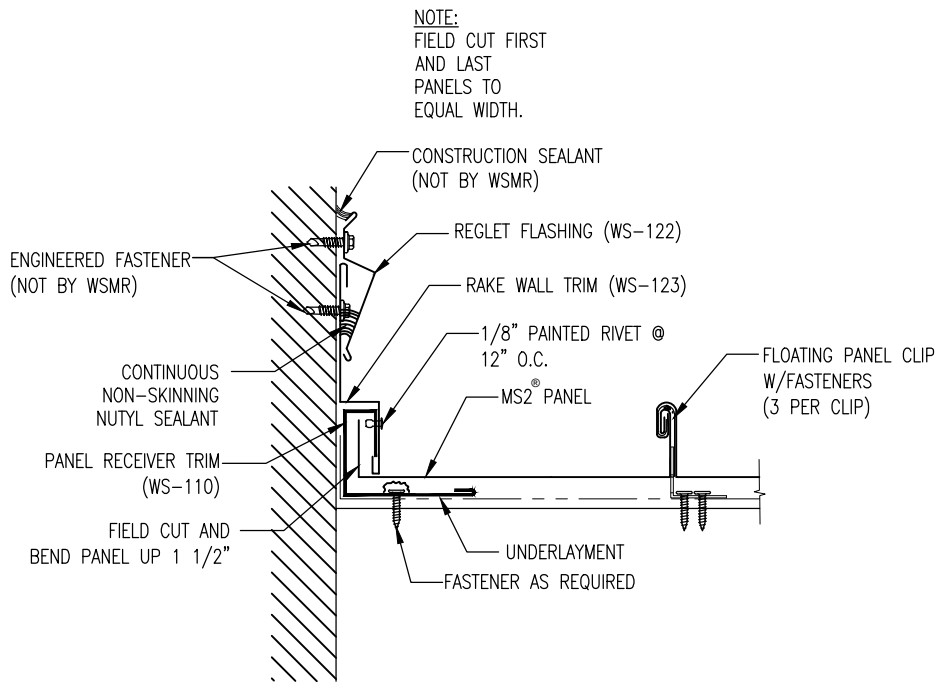

| | |
|-----------------|---------------|
| GAUGE: _____ | COLOR: _____ |
| LENGTH: _____ | FINISH: _____ |
| MATERIAL: _____ | |

Western States Metal Roofing

901 W. Watkins St. Phone: (602) 495-0048
 Phoenix, AZ 85007 Fax: (602) 261-7726
 www.MetalForRoofing.com 877-PURLINS (787-5467)
 www.PaintedRustedRoofing.com
 www.MetalDeck.com

| | | |
|-----------------------------------|--------------------------|----------|
| RAKE WALL DETAIL (180° SEAM) | | |
| | A | 04-08-19 |
| PANEL TYPE: MS2® STANDING SEAM | REV: | DATE: |
| | DETAIL #: MS2-WSD-W16 | |

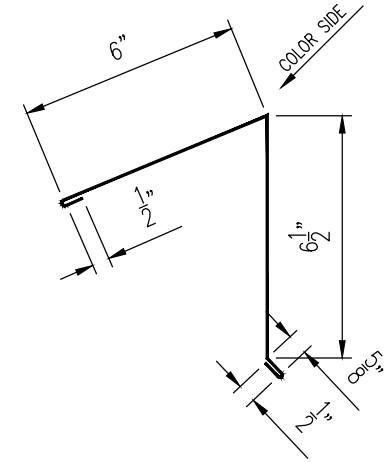
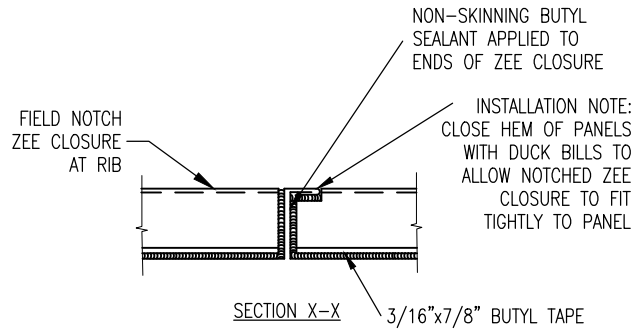

HIGH EAVE FLASH (WS-125)

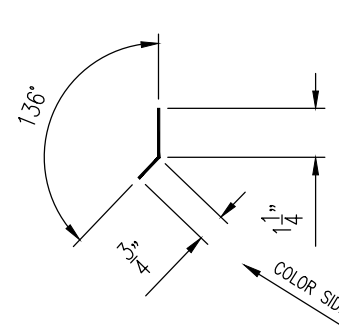
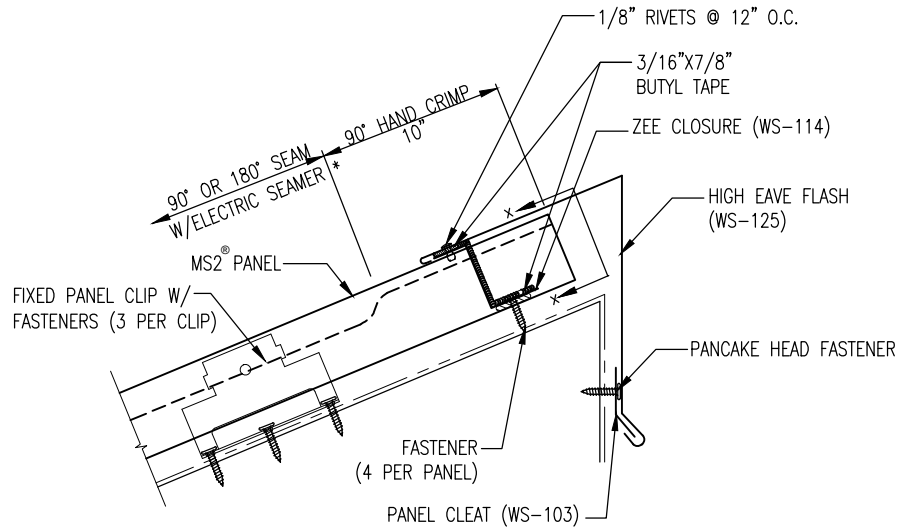

PANEL CLEAT
(WS-103)

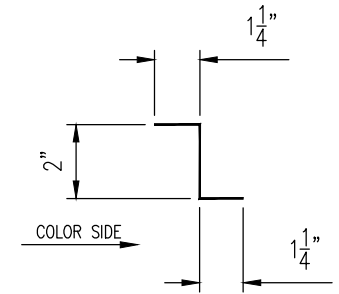

ZEE CLOSURE (WS-114)

| | |
|-----------------|---------------|
| GAUGE: _____ | COLOR: _____ |
| LENGTH: _____ | FINISH: _____ |
| MATERIAL: _____ | |

Western States Metal Roofing

901 W. Watkins St.

Phone: (602) 495-0048

Phoenix, AZ 85007

Fax: (602) 261-7726

www.MetalForRoofing.com

877-PURLINS (787-5467)

www.PaintedRustedRoofing.com

www.MetalDeck.com

| | | |
|-----------------------------------|--------------------------|----------|
| HIGH EAVE DETAIL (FIXED) | | |
| | A | 04-08-19 |
| PANEL TYPE: MS2® STANDING SEAM | REV: | DATE: |
| | DETAIL #: MS2-WSD-W17 | |

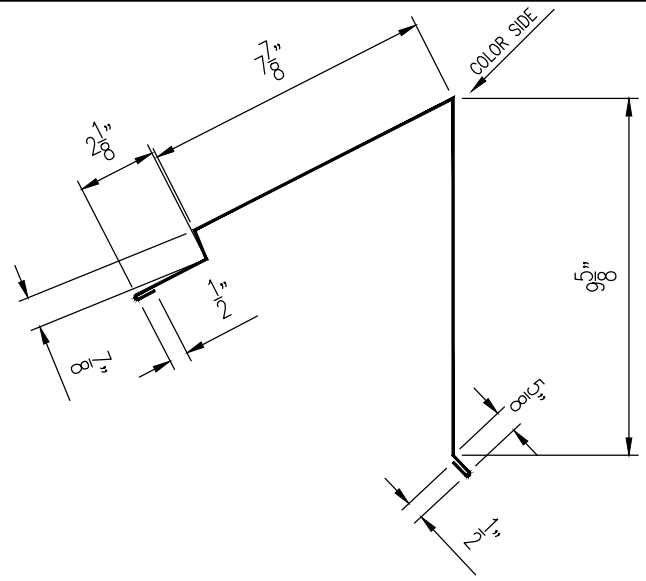
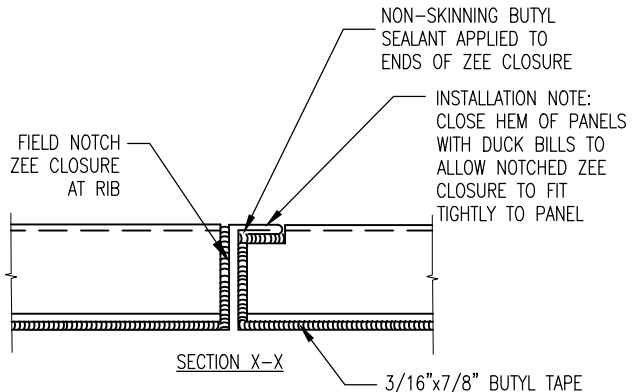

HIGH EAVE FLASH (WS-126)

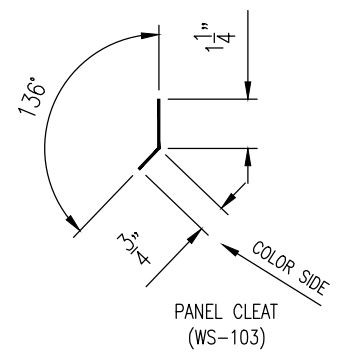
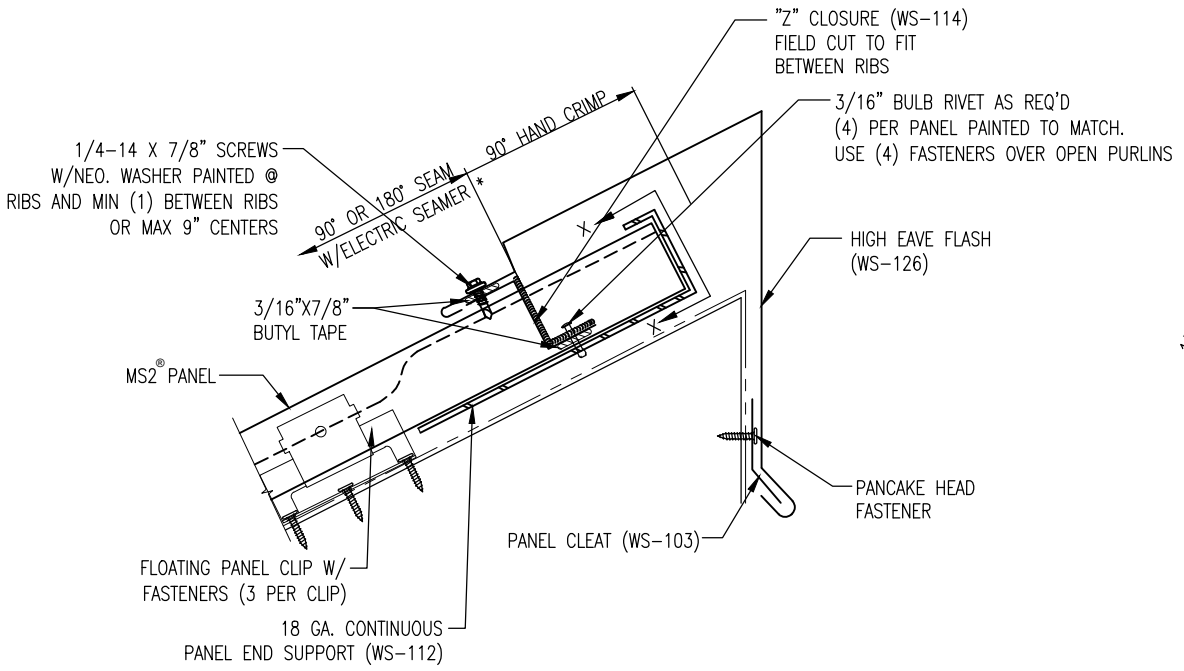

PANEL CLEAT (WS-103)

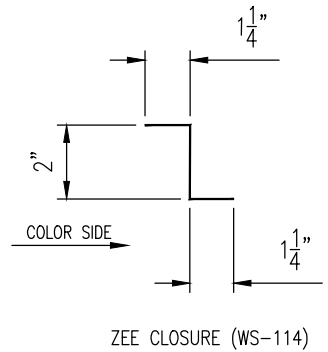

ZEE CLOSURE (WS-114)

| | |
|-----------------|---------------|
| GAUGE: _____ | COLOR: _____ |
| LENGTH: _____ | FINISH: _____ |
| MATERIAL: _____ | |

Western States Metal Roofing

901 W. Watkins St. Phone: (602) 495-0048
 Phoenix, AZ 85007 Fax: (602) 261-7726
 www.MetalForRoofing.com 877-PURLINS (787-5467)
 www.PaintedRustedRoofing.com
 www.MetalDeck.com

| | | |
|-----------------------------------|-----------|-------------|
| HIGH EAVE DETAIL (FLOATING) | | |
| | A | 04-08-19 |
| PANEL TYPE: MS2® STANDING SEAM | REV: | DATE: |
| | DETAIL #: | MS2-WSD-W18 |

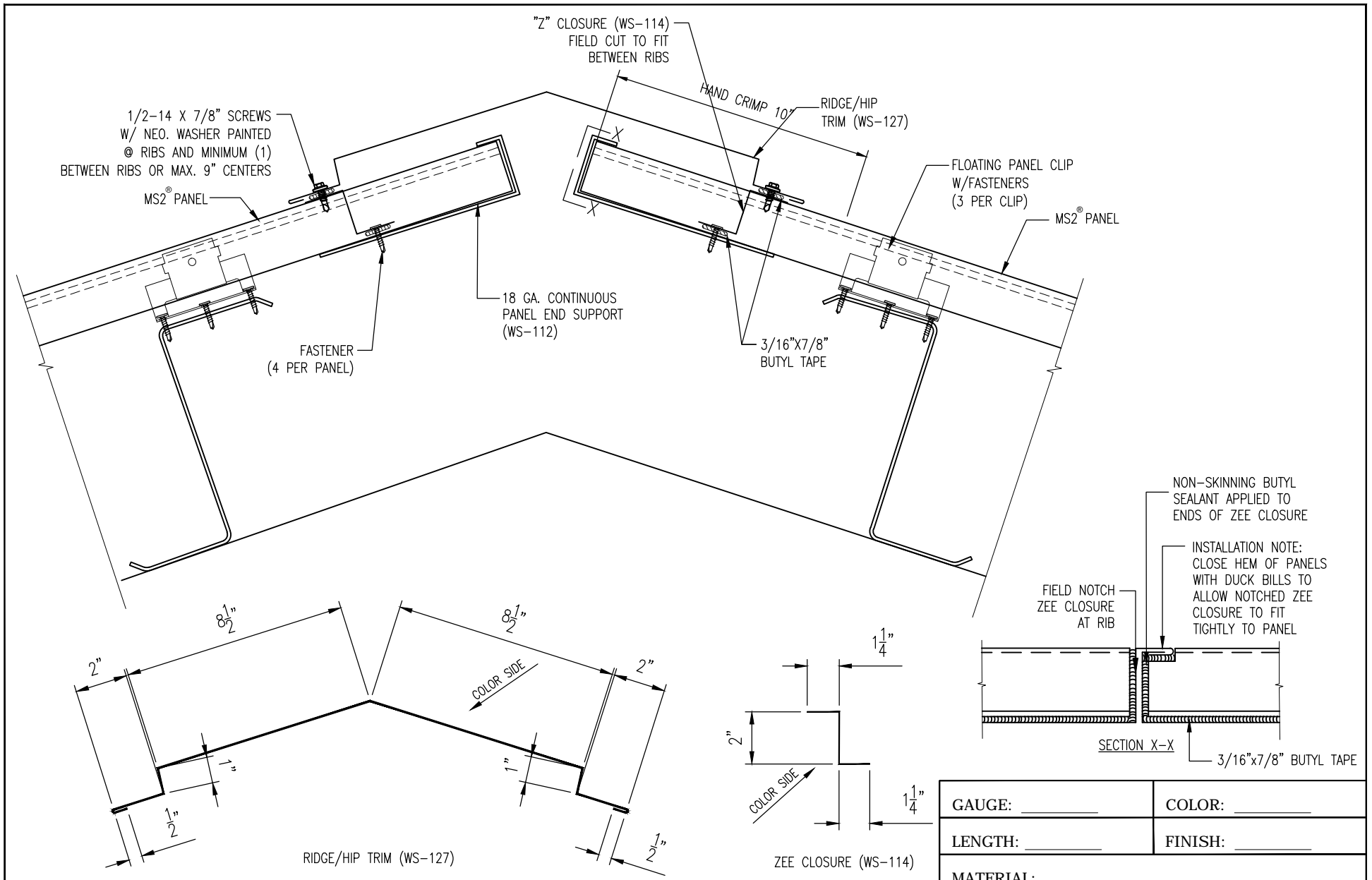

| | |
|-----------------|---------------|
| GAUGE: _____ | COLOR: _____ |
| LENGTH: _____ | FINISH: _____ |
| MATERIAL: _____ | |

Western States Metal Roofing

901 W. Watkins St. Phone: (602) 495-0048
 Phoenix, AZ 85007 Fax: (602) 261-7726
 www.MetalForRoofing.com 877-PURLINS (787-5467)
 www.PaintedRustedRoofing.com
 www.MetalDeck.com

| | | |
|---|-----------|-------------|
| RIDGE DETAIL (FLOATING) | | |
| | A | 04-08-19 |
| PANEL TYPE: MS2 [®] STANDING SEAM | REV: | DATE: |
| | DETAIL #: | MS2-WSD-W19 |

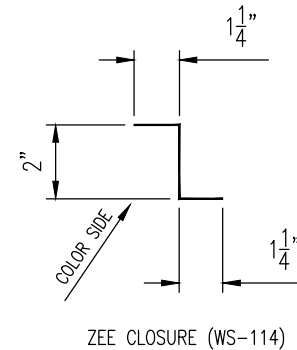
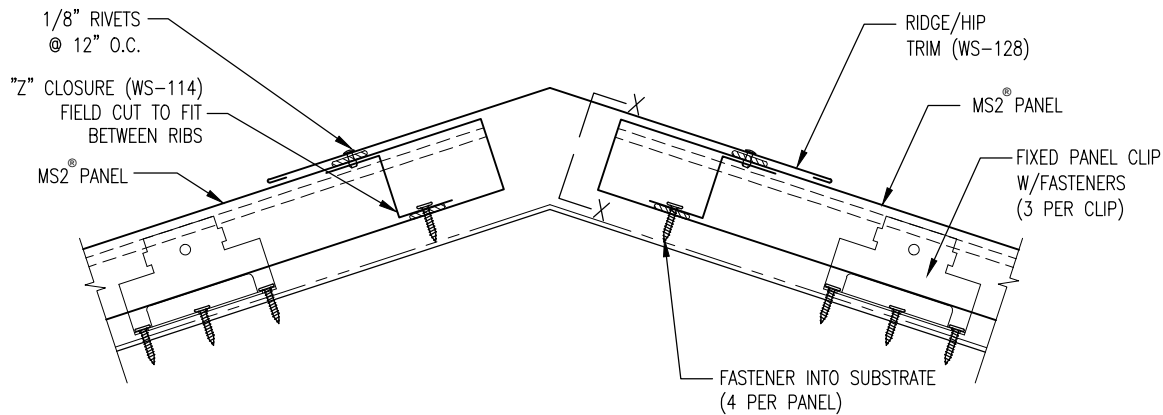
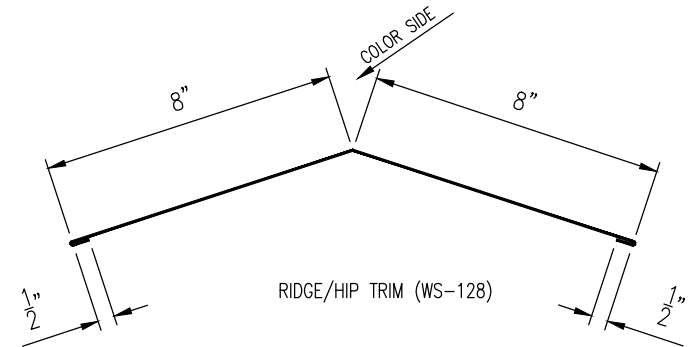
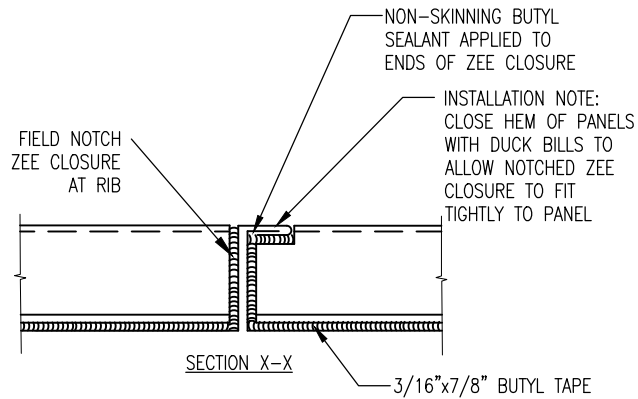

| | |
|-----------------|---------------|
| GAUGE: _____ | COLOR: _____ |
| LENGTH: _____ | FINISH: _____ |
| MATERIAL: _____ | |

Western States Metal Roofing

901 W. Watkins St. Phone: (602) 495-0048
 Phoenix, AZ 85007 Fax: (602) 261-7726
 www.MetalForRoofing.com 877-PURLINS (787-5467)
 www.PaintedRustedRoofing.com
 www.MetalDeck.com

| | | |
|-----------------------------------|--------------------------|----------|
| RIDGE DETAIL (FIXED) | | |
| | A | 04-08-19 |
| PANEL TYPE: MS2® STANDING SEAM | REV: | DATE: |
| | DETAIL #: MS2-WSD-W20 | |

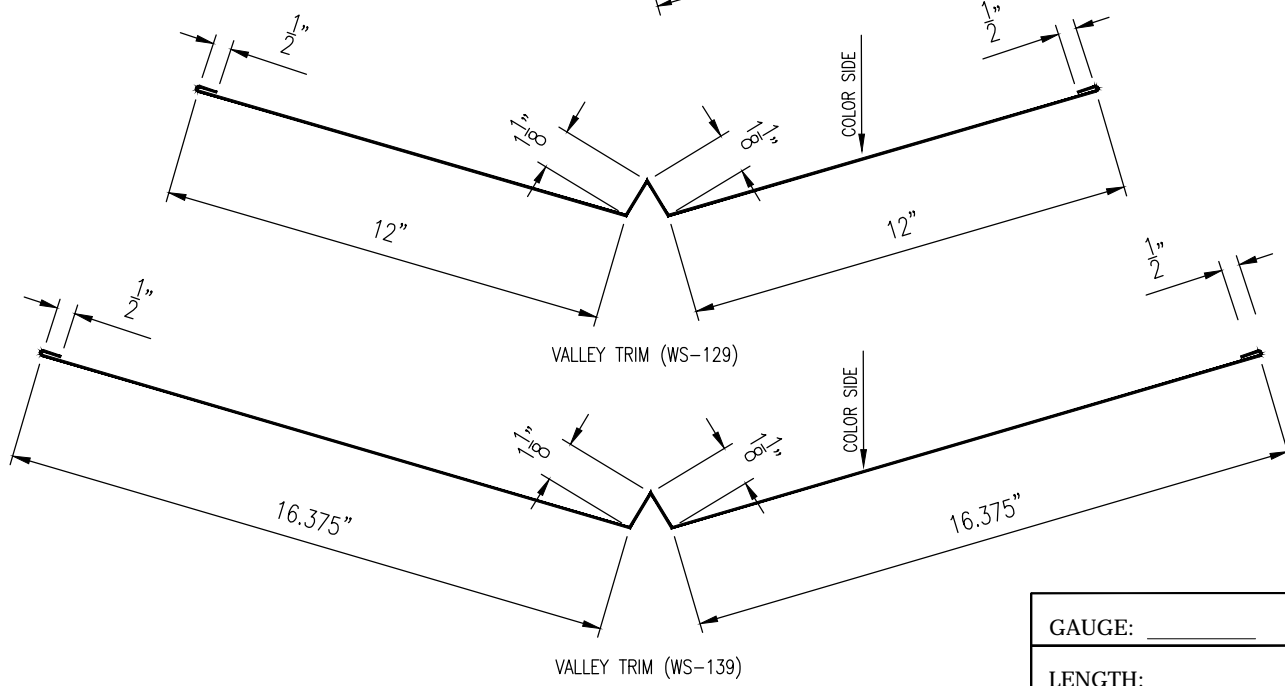
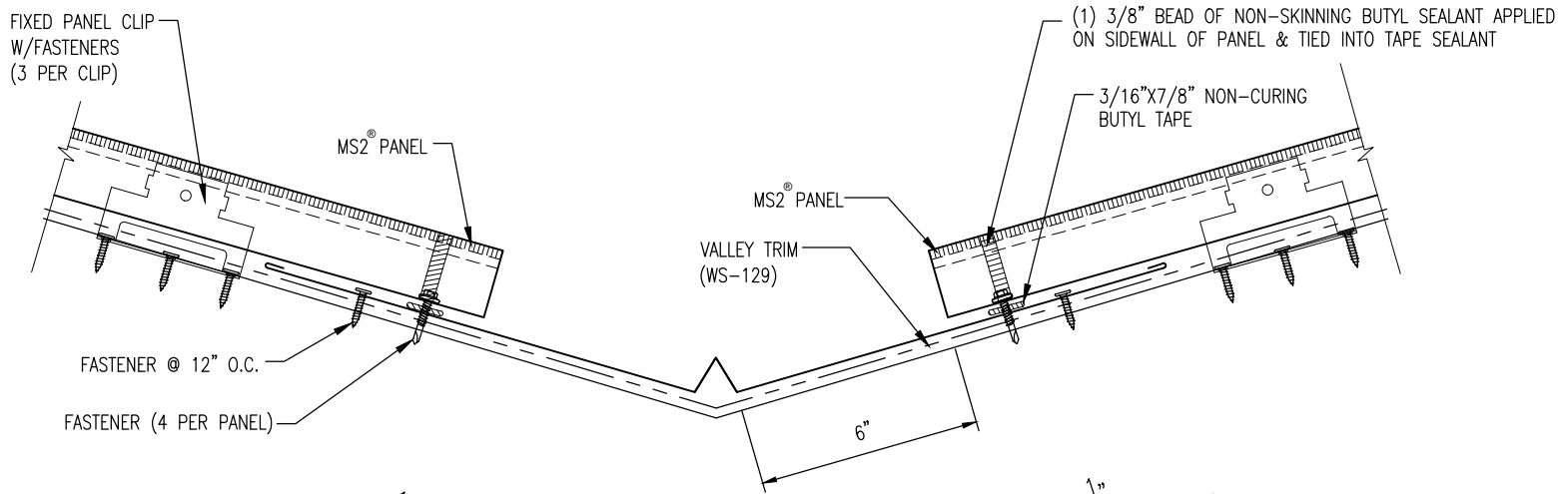

| | |
|-----------------|---------------|
| GAUGE: _____ | COLOR: _____ |
| LENGTH: _____ | FINISH: _____ |
| MATERIAL: _____ | |

Western States Metal Roofing

901 W. Watkins St. Phone: (602) 495-0048
 Phoenix, AZ 85007 Fax: (602) 261-7726
 www.MetalForRoofing.com 877-PURLINS (787-5467)
 www.PaintedRustedRoofing.com
 www.MetalDeck.com

| | | |
|-----------------------------------|--------------------------|----------|
| VALLEY DETAIL (FIXED) | | |
| | A | 04-08-19 |
| PANEL TYPE: MS2® STANDING SEAM | REV: | DATE: |
| | DETAIL #: MS2-WSD-W21 | |

FLOATING PANEL CLIP
W/FASTENERS
(3 PER CLIP)

MS2® PANEL

JOGGLE CLEAT (WS-105)

3/16"X7/8" NON CURING
BUTYL TAPE

MS2® PANEL

VALLEY TRIM (WS-129)

FASTENER @ 12" O.C.

FIELD NOTCH 1" MINIMUM
AND HEM UNDER

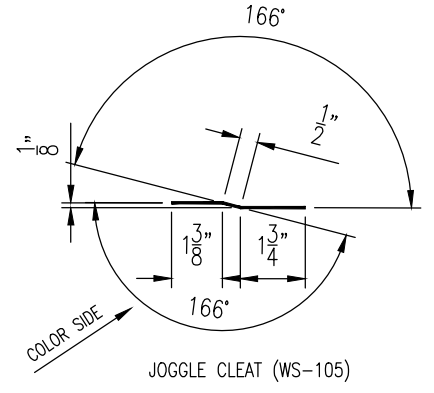
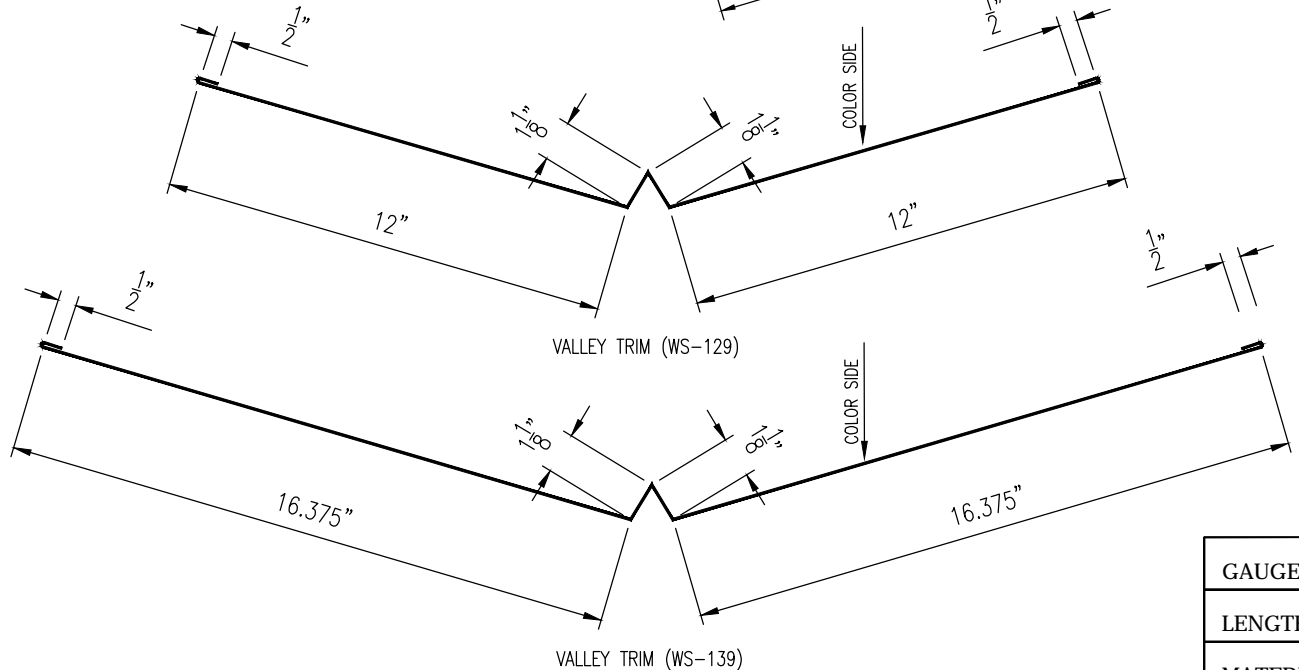

| | |
|-----------------|---------------|
| GAUGE: _____ | COLOR: _____ |
| LENGTH: _____ | FINISH: _____ |
| MATERIAL: _____ | |

Western States Metal Roofing

901 W. Watkins St. Phone: (602) 495-0048
 Phoenix, AZ 85007 Fax: (602) 261-7726
 www.MetalForRoofing.com 877-PURLINS (787-5467)
 www.PaintedRustedRoofing.com
 www.MetalDeck.com

| | | |
|-----------------------------------|-----------|-------------|
| VALLEY DETAIL (FLOATING) | | |
| | A | 04-08-19 |
| PANEL TYPE: MS2® STANDING SEAM | REV: | DATE: |
| | DETAIL #: | MS2-WSD-W22 |

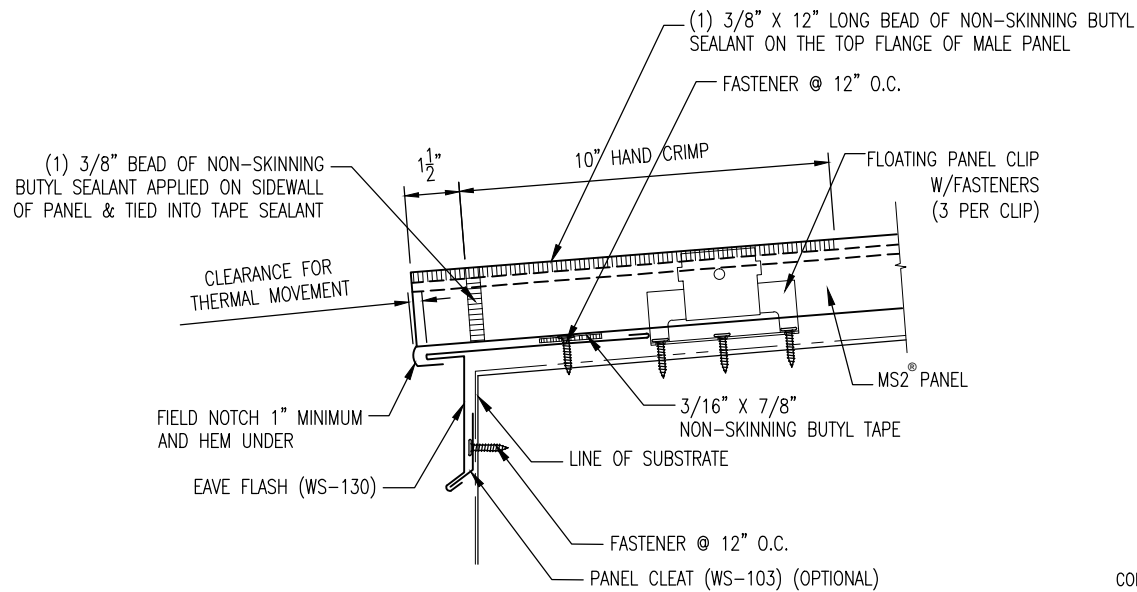

* 6" MAX CLIP PLACEMENT FROM END OF PANEL

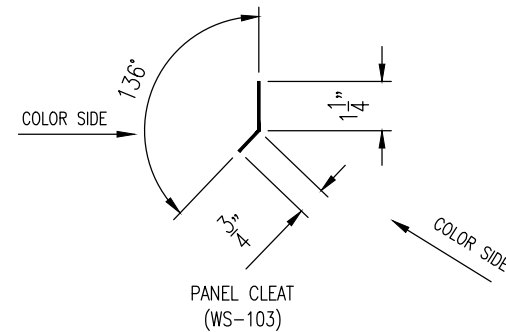
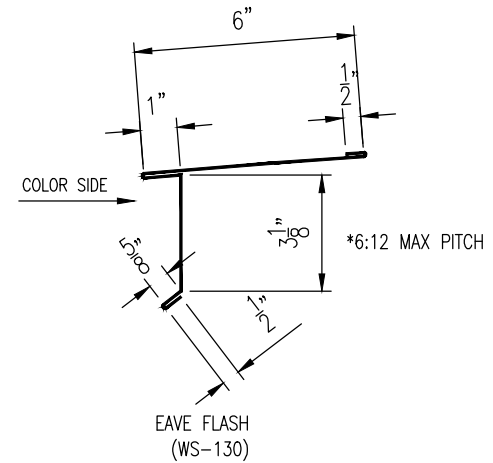

| | |
|-----------------|---------------|
| GAUGE: _____ | COLOR: _____ |
| LENGTH: _____ | FINISH: _____ |
| MATERIAL: _____ | |

Western States Metal Roofing

901 W. Watkins St.

Phone: (602) 495-0048

Phoenix, AZ 85007

Fax: (602) 261-7726

www.MetalForRoofing.com

877-PURLINS (787-5467)

www.PaintedRustedRoofing.com

www.MetalDeck.com

BULL NOSE EAVE DETAIL

PANEL TYPE:

MS2® STANDING SEAM

A 04-08-19

REV: DATE:

DETAIL #:
MS2-WSD-W23

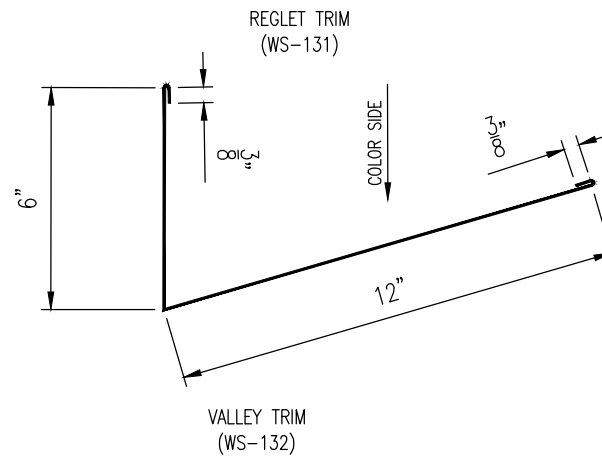
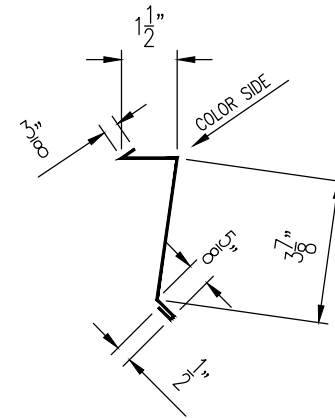
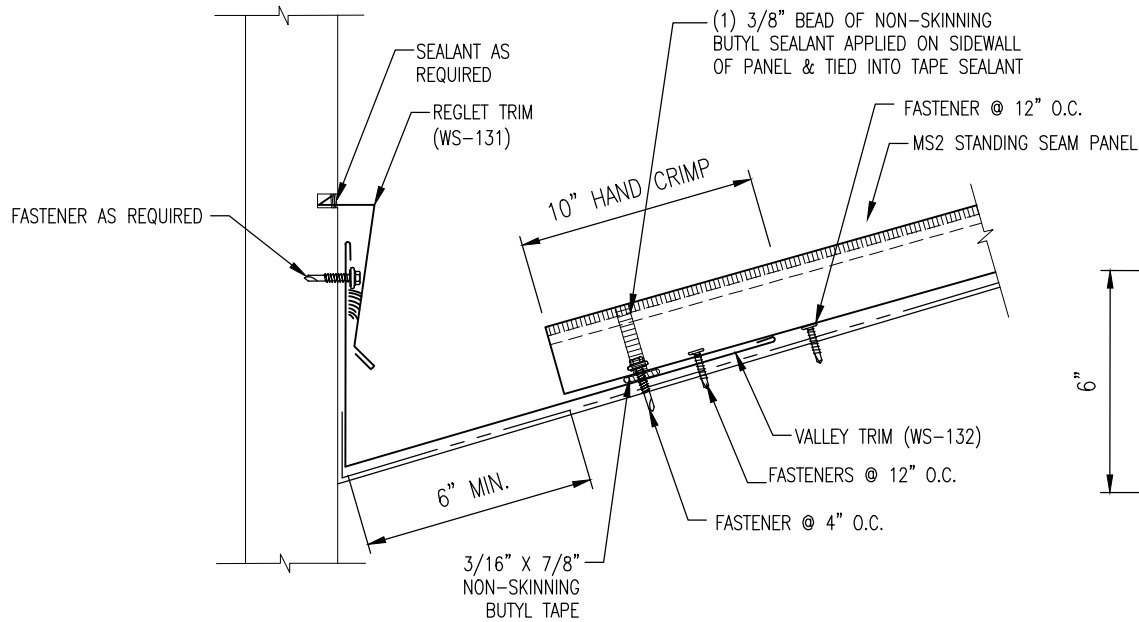

| | |
|-----------------|---------------|
| GAUGE: _____ | COLOR: _____ |
| LENGTH: _____ | FINISH: _____ |
| MATERIAL: _____ | |

Western States Metal Roofing

901 W. Watkins St. Phone: (602) 495-0048
 Phoenix, AZ 85007 Fax: (602) 261-7726
 www.MetalForRoofing.com 877-PURLINS (787-5467)
 www.PaintedRustedRoofing.com
 www.MetalDeck.com

| | | |
|-----------------------------------|--------------------------|----------|
| HALF VALLEY DETAIL (FIXED) | | |
| | A | 04-08-19 |
| PANEL TYPE: MS2® STANDING SEAM | REV: | DATE: |
| | DETAIL #: MS2-WSD-W24 | |

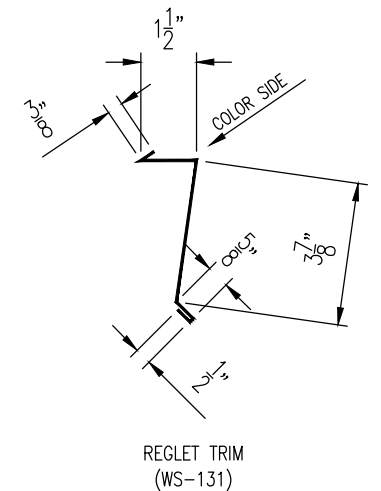
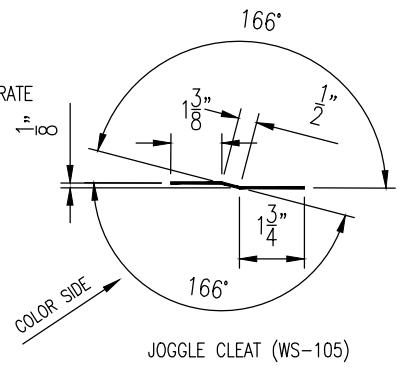
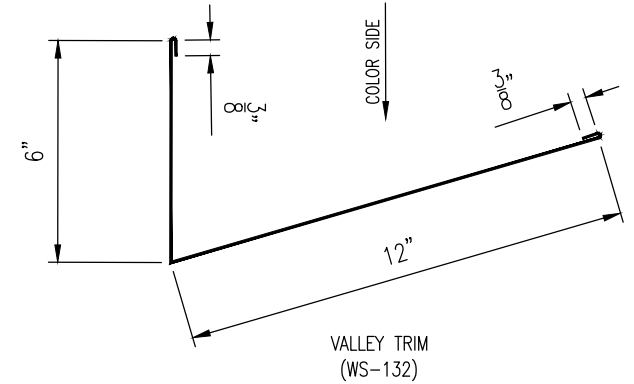
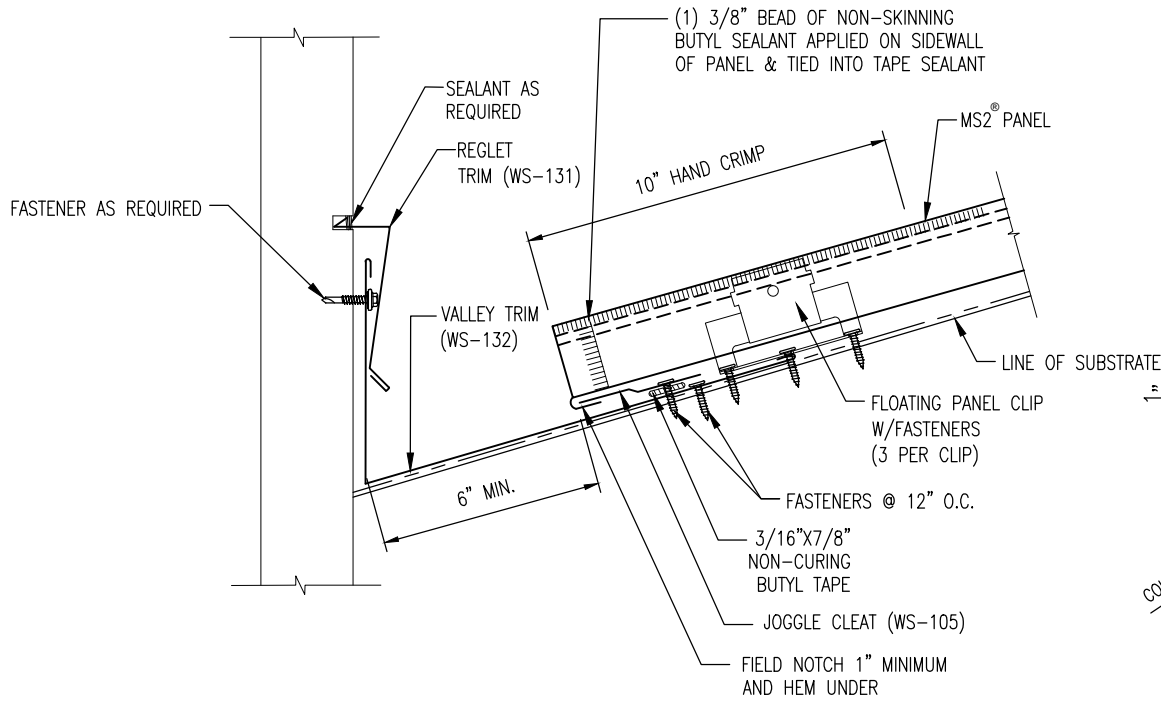

* 6" MAX CLIP PLACEMENT FROM END OF PANEL

| | |
|-----------------|---------------|
| GAUGE: _____ | COLOR: _____ |
| LENGTH: _____ | FINISH: _____ |
| MATERIAL: _____ | |

Western States Metal Roofing

901 W. Watkins St. Phone: (602) 495-0048
 Phoenix, AZ 85007 Fax: (602) 261-7726
 www.MetalForRoofing.com 877-PURLINS (787-5467)
 www.PaintedRustedRoofing.com
 www.MetalDeck.com

| | | |
|-----------------------------------|--------------------------|----------|
| HALF VALLEY DETAIL (FLOATING) | | |
| | A | 04-08-19 |
| PANEL TYPE: MS2® STANDING SEAM | REV: | DATE: |
| | DETAIL #: MS2-WSD-W25 | |

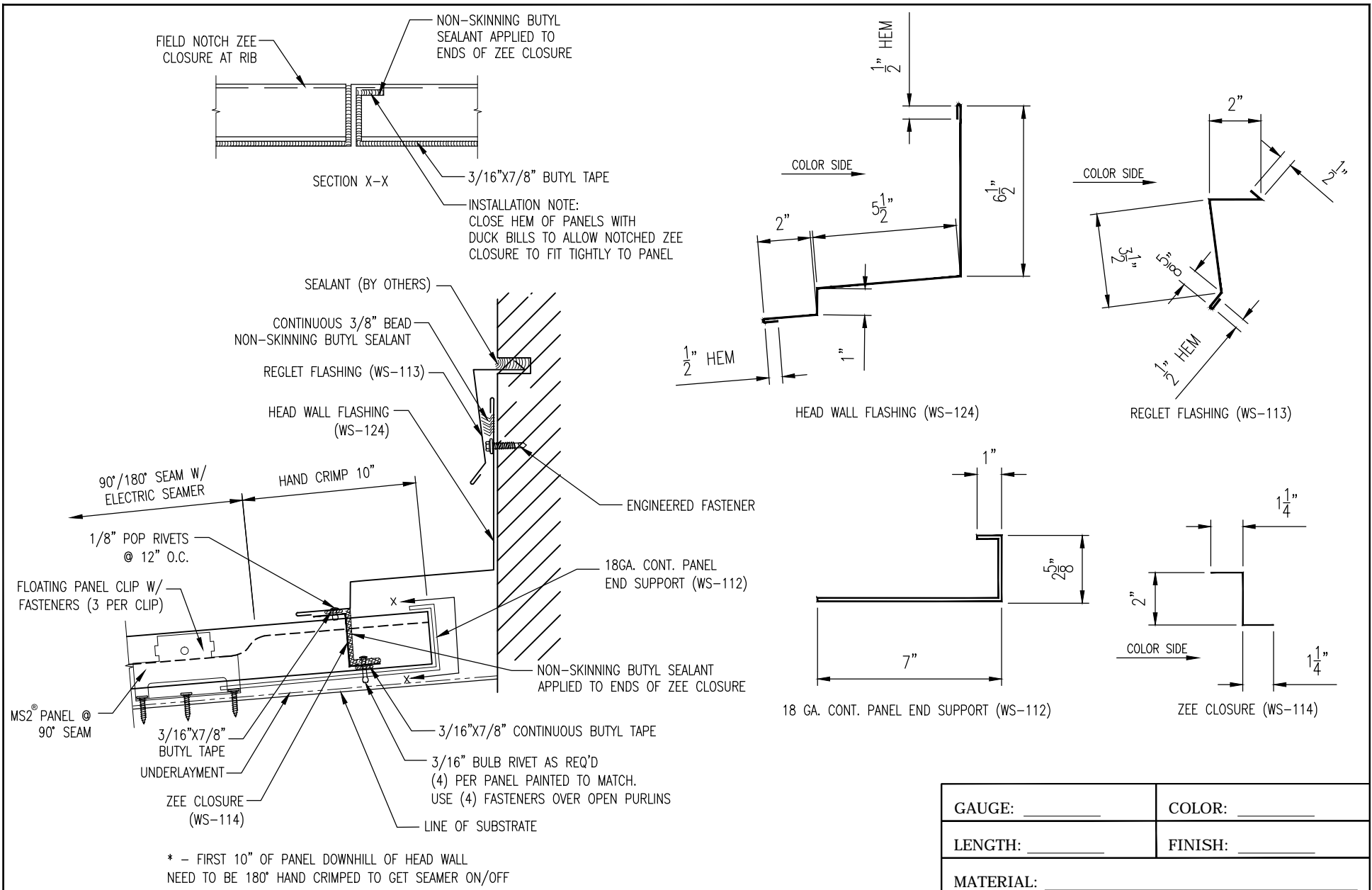

| | |
|-----------------|---------------|
| GAUGE: _____ | COLOR: _____ |
| LENGTH: _____ | FINISH: _____ |
| MATERIAL: _____ | |

Western States Metal Roofing

901 W. Watkins St. Phone: (602) 495-0048
 Phoenix, AZ 85007 Fax: (602) 261-7726
 www.MetalForRoofing.com 877-PURLINS (787-5467)
 www.PaintedRustedRoofing.com
 www.MetalDeck.com

| | | |
|-----------------------------------|--------------------------|----------|
| HEAD WALL DETAIL (FLOATING) | | |
| | A | 04-08-19 |
| PANEL TYPE: MS2® STANDING SEAM | REV: | DATE: |
| | DETAIL #: MS2-WSD-W26 | |

NOTES:

Western States Metal Roofing

901 W. Watkins St.

Phone: (602) 495-0048

Phoenix, AZ 85007

Fax: (602) 261-7726

www.MetalForRoofing.com

877-PURLINS (787-5467)

www.PaintedRustedRoofing.com

www.MetalDeck.com

NOTES

PANEL TYPE:

MS2[®] STANDING SEAM

A 04-08-19

REV: DATE:

DETAIL #:

CUSTOM TRIM

| | | |
|---|--------------------|----------|
| GAUGE: _____ | COLOR: _____ | |
| BREAKS: _____ | FINISH: _____ | |
| LENGTH: _____ | STRETCH OUT: _____ | |
| MATERIAL: _____ | | |
| CUSTOM TRIM NAME: _____ | | |
| | A | 04-08-19 |
| PANEL TYPE: MS2 [®] STANDING SEAM | REV: | DATE: |
| | DETAIL #: | |

Western States Metal Roofing

901 W. Watkins St. Phone: (602) 495-0048
 Phoenix, AZ 85007 Fax: (602) 261-7726
 www.MetalForRoofing.com 877-PURLINS (787-5467)
 www.PaintedRustedRoofing.com
 www.MetalDeck.com



Finishes You've Never Seen Before®

WESTERN STATES METAL ROOFING

(877) 787-5467 • WESTERNSTATESMETALROOFING.COM

REQUEST A FREE METAL COLOR SAMPLE

Affordable Delivery throughout USA, Canada, and Mexico

Phoenix: 901 W Watkins St., Phoenix, AZ 85007

☎ (602) 495-0048

✉ sales@westernstatesmetalroofing.com

Tucson: 4975 E. Drexel Rd., Tucson, AZ 85706

☎ (520) 574-4247

✉ tucsonsales@westernstatesmetalroofing.com



www.facebook.com/westernstatesmetalroofing/



www.instagram.com/westernstatesmetalroofing/



www.twitter.com/weststatesmetal



www.youtube.com/westernstatesmetalroofing



www.linkedin.com/company/western-states-metal-roofing



www.pinterest.com/westernstatesmetalroofing/



www.houzz.com/pro/raynaann/western-states-metal-roofing